



# FRAMED SYSTEMS

Framed systems  
Sistemas con marcos

NEW  
RELEASE



# Indice

## Index | Índice



### Tabula

Profilo porta battente  
Door frame  
Perfil puerta

4



### WCP7

Parete vetrata  
Glass wall partition  
Pared de vidrio

36



### 41AL

Parete vetrata  
Glass wall partition  
Pared de vidrio

50



### 41AL-XL

Parete vetrata  
Glass wall partition  
Pared de vidrio

58



### Tabula

Profilo porta scorrevole  
Sliding system  
Sistema deslizando

59

# Finiture e legenda

## Finishing and legenda

### Finiture standard

Standard finishings | Acabados estandar

Alluminio | Aluminum

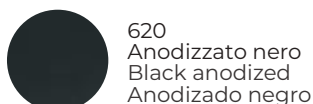
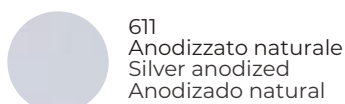

### Su richiesta

Upon request | Bajo pedido



Gamma completa di colori disponibili su richiesta  
Range of colors available upon request  
Gama completa de colores disponibles bajo demanda/pedido

### Finiture speciali

Special finishings | Acabados especiales

Alluminio | Aluminum

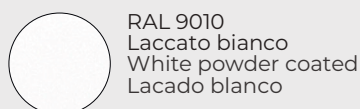
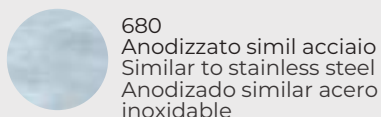
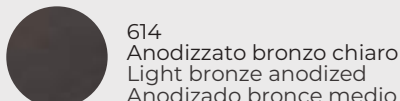
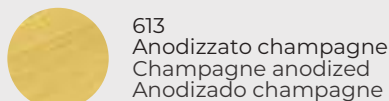

### Finiture guarnizioni

Gasket finishings  
Acabados juntas



### Legenda | Legend | Leyenda



Testato a 100.000 cicli come previsto da EN 152  
Tested at 100.000 cycles as required by the UNI EN 1527  
Testado a 100.000 cycles como UNI EN 1527



Opzionale | dettagli tecnici che influiscono sulla funzionalità  
Optional | Technical details that affect the functionality  
Opcional | indicaciones técnicas que afectan el funcionamiento



Brevettato  
Patented  
Patentado



SOFT CLOSE  
Soft close



Garantito per tre anni  
Guarantee for 3 years  
Garantido en 3 años



Certificazione di abbattimento del rumore  
Noise abatement certification  
Certificación de reducción del ruido



Regolazione in altezza  
Height adjustment  
Regulación en altura





Spessore vetro  
Glass thickness  
Espesor del vidrio

8 ÷ 12,5 mm\*

5/16 ÷ 15/32"\*

\*Ulteriori spessori su richiesta  
\*More thicknesses upon request  
\*Más espesores bajo pedido



Portata  
Weight  
Peso

100 kg  
247,50 Lbs



Max. altezza anta  
Max. door width  
Max. altura de la puerta

3000 mm\*

118 7/64" \*

\*Ulteriori altezze su richiesta  
\*More heights upon request  
\*Más alturas bajo pedido



EN1127

100.000 cicli  
100.000 cycles  
100.000 ciclos



Larghezza anta  
Door width  
Ancho de la puerta

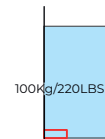

550 ÷ 1000 mm  
21 21/32 ÷ 39 3/8"

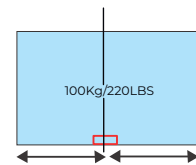

1000 + 1000 mm  
39 3/8" + 39 3/8"

Finiture  
standard  
Standard  
finishes  
Acabados  
estándar

611

Alluminio  
anodizzato  
naturale  
Silver anodized  
aluminum  
Aluminio  
anodizado  
natural

620

Alluminio  
anodizzato nero  
Black anodized  
aluminum  
Aluminio  
anodizado negro



Mano sinistra interna  
Left hand In-swing (DIN)  
Interior izquierda



Mano sinistra esterna  
Left hand Out-swing (DIN)  
Exterior izquierda



Mano destra interna  
Right hand In-swing (DIN)  
Interior derecha



Mano destra esterna  
Right hand Out-swing (DIN)  
Exterior derecha

## Profilo porta 1 Door profile 1 | Perfil puerta 1

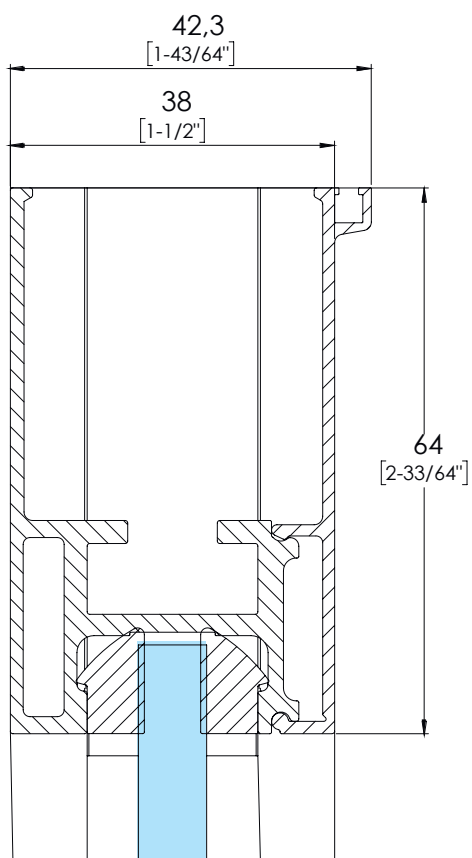

## Profilo porta 2 Door profile 2 | Perfil puerta 2

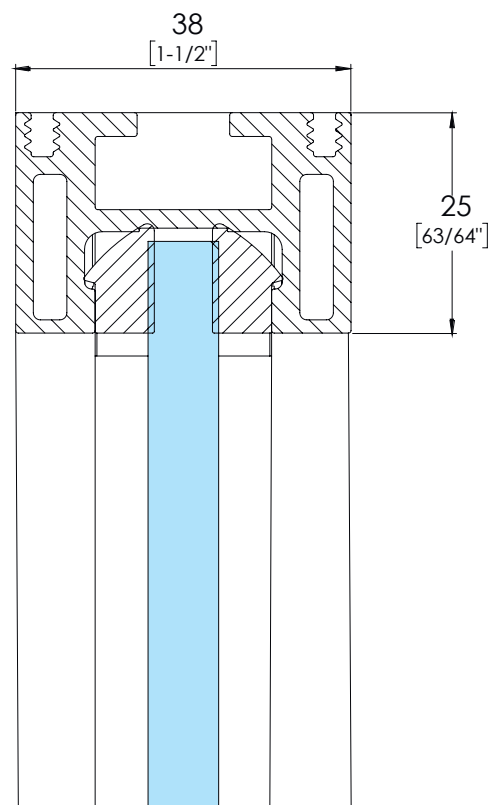

# Profilo porta 1

Door profile 1 | Perfil puerta 1

Opzione cerniera idraulica o pivot | Sez. tecnica

Hydraulic option or with pivot | Technical section  
Opción bisagra hidráulica o rotación | Sección técnica

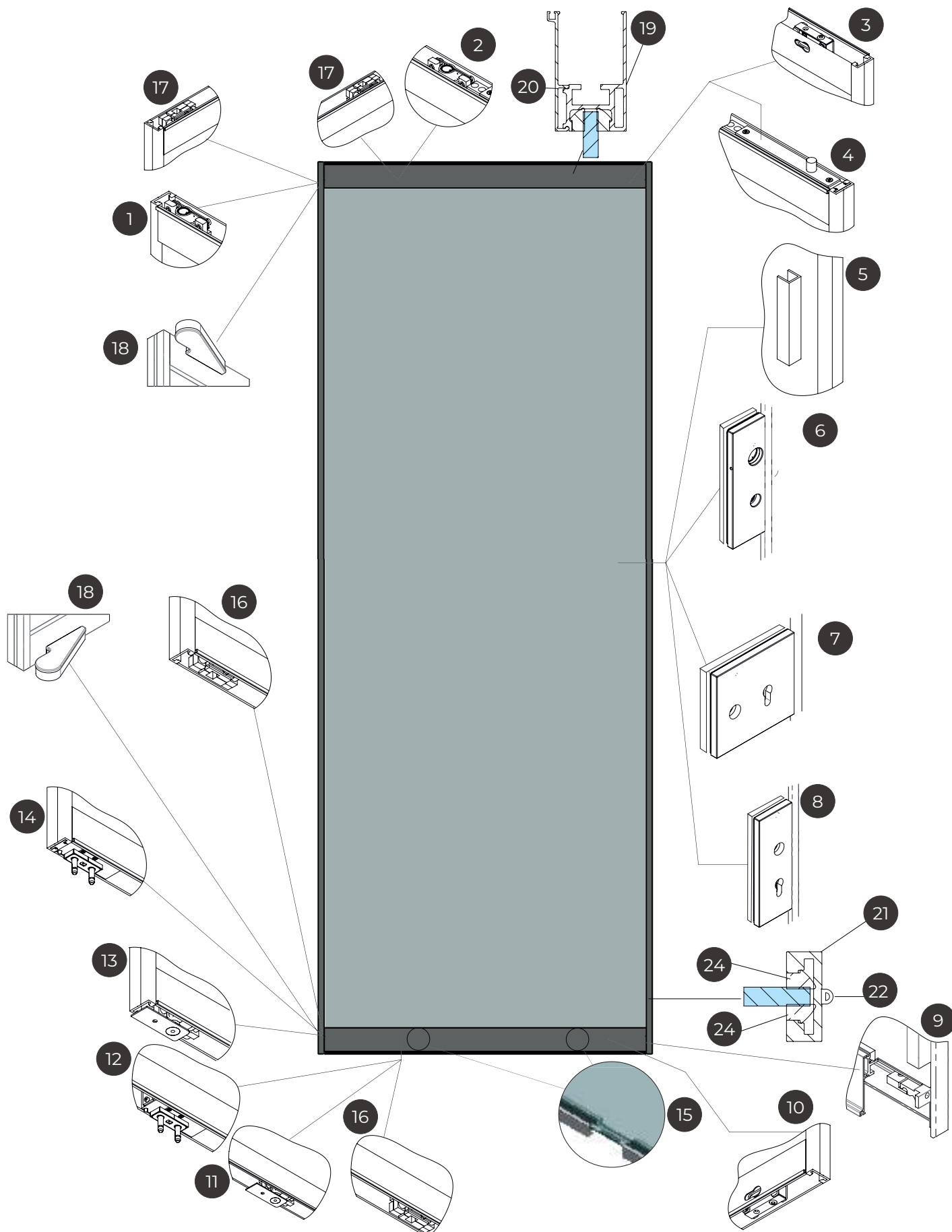

# Profilo porta 1

## Door profile 1 | Perfil puerta 1

### Opzione cerniera idraulica o pivot | Sez. tecnica

Hydraulic option or with pivot | Technical section  
Opción bisagra hidráulica o rotación | Sección técnica

**1** **TB40A** **10180 | 10150\***

Kit supporto pivot sup. a bilico o angolo  
Corner and displaced kit for top pivot slot  
Kit de soporte para sistema de rotación superior en esquina o desplazado  
\*Compatible con serratura elettrica  
Compatible with electric lock  
Compatible con cerradura electrónica

Perno di rotazione sup.  
Upper pivot  
Rotación superior



**2** **TB40A** **10180 | 10150\***

Kit supporto pivot sup. a bilico o angolo  
Corner and displaced kit for top pivot slot  
Kit de soporte para sistema de rotación superior en esquina o desplazado  
\*Compatible con serratura elettrica  
Compatible with electric lock  
Compatible con cerradura electrónica

Perno di rotazione sup.  
Upper pivot  
Rotación superior



**3** **TB34A**

Kit serratura a bilico  
Displaced lock slot  
Kit cerradura desplazado

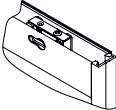

**4** **TB35A TB36A**

Kit serratura elettrica  
Electric lock kit  
Kit cerradura electrónica



**5** **TB43A**

Coppia di maniglie a incollare  
Pair of handles to be glued  
Par de manetas para pegar

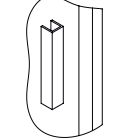

**6** **TB37A TBA7A**

Serratura verticale US  
US Vertical lock  
Cerradura vertical US

**i** Disponibile con funzione  
Functions F01, F12, F21, F31 ANSI BAMA 156.13-2017



**7** **TB39A TBA9A**

Serratura orizzontale EU  
EU Horizontal lock  
Cerradura horizontal EU



**8** **TB38A TBA8A**

Serratura verticale EU  
EU Vertical lock  
Cerradura vertical EU



**9** **TB16A**

Kit 4 angoli telaio  
4 Corner door frame kit  
Kit 4 esquinas marco de puerta

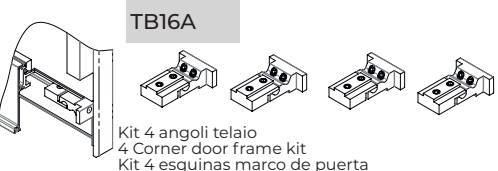

**10** **TB34A**

Kit serratura a bilico  
Displaced lock slot  
Kit cerradura desplazado

**i** Traversa TB54A e copertina TB56A intestate per serratura non incluse  
Pre-drilled for lock track TB54A and cover TB56A not included  
Traversaño TB54A y cubierta TB56A preperforados para cerradura no incluidos

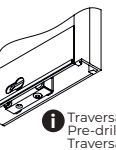

**11** **TB31A**

Cerniera pivotante ad angolo o a bilico  
Bottom corner and displaced pivot  
Sistema de rotación en esquina y desplazado



**12** **TB30A** **4FXXN**

Kit supporto per cerniera idraulica  
Frenum a bilico  
Displaced hydraulic hinge Frenum support kit  
Kit soporte para bisagra hidráulica  
Frenum desplazada

Cerniera idraulica  
Hydraulic hinge  
Bisagra hidráulica

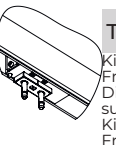

**13** **TB31A**

Cerniera pivotante ad angolo o a bilico  
Bottom corner and displaced pivot  
Sistema de rotación en esquina y desplazado

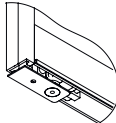

**14** **TB29A** **4FXXN**

Kit supporto per cerniera idraulica Frenum ad angolo  
Corner hydraulic hinge Frenum support kit  
Kit soporte para bisagra hidráulica Frenum en esquina

Cerniera idraulica  
Hydraulic hinge  
Bisagra hidráulica

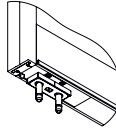

**15** **TB19A**

Coppia di spessori per supporto vetro  
Pair of glass supports  
Par de soportes para vidrio

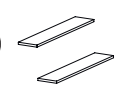

**16** **TB85A**

Supporto per chiudiporta a bilico e ad angolo  
Support for displaced and corner floor spring  
Soporte para cierrapuerta desplazado y en esquina

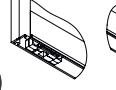

**M25** **M60** **KS3000**

Chiudiporta  
Floor spring  
Cierrapuerta

Chiudiporta  
Floor spring  
Cierrapuerta

Chiudiporta  
Floor spring  
Cierrapuerta



**17** **TB85A** **M77**

Supporto per chiudiporta RTS  
Concealed door closer  
Soporte para cierrapuerta RTS

Chiudiporta RTS  
Concealed door closer  
Cierrapuerta RTS

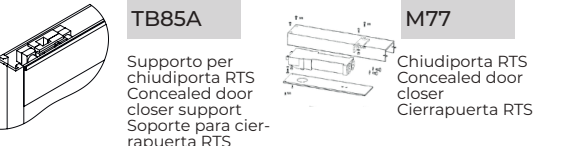

**18** **TB83A** **TB84A**

Sbalzo sup. e inf. Upper an lower offset pivot  
Rotación superior y inferior con eje desplazado  
DIN L

Sbalzo sup. e inf. Upper an lower offset pivot  
Rotación superior y inferior con eje desplazado  
DIN R



**M25** **M60** **KS3000**

Chiudiporta  
Floor spring  
Cierrapuerta

Chiudiporta  
Floor spring  
Cierrapuerta

Chiudiporta  
Floor spring  
Cierrapuerta



**19** **TB21A** **TB09A**

Traversa  
Track  
Traversaño

Guarnizione tenuta  
Gasket  
Junta para insertar



**20** **TB22A** **TB20A**

Coperchio traversa  
Cover for frame  
Tapa para traversaño

Spazzola a infilare  
Brush gasket for frame  
Cepillo para perfil



**21** **TB06A** **TB20A** **TB09A**

Montante  
Door frame  
Perfil

Spazzola a infilare  
Brush gasket for door profile  
Junta de cepillo

Guarnizione tenuta  
Gasket  
Junta para insertar

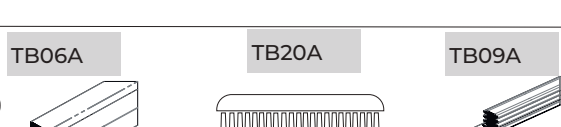

**22** **TB10A**

Guarnizione adesiva di testa  
Head gasket to be glued  
Junta a pegar



**23** **TB08A**

Guarnizione per ferma-vetro  
Gasket for glass fixing  
Junta para vidrio



**i** Opzionale | Optional | Opcional

# Configurazioni possibili

Possible configurations | Configuraciones posibles

Profilo porta 1 | Door profile 1 | Perfil puerta 1

**Cerniera idraulica laterale**

Hydraulic corner hinge  
Bisagra hidráulica en esquina

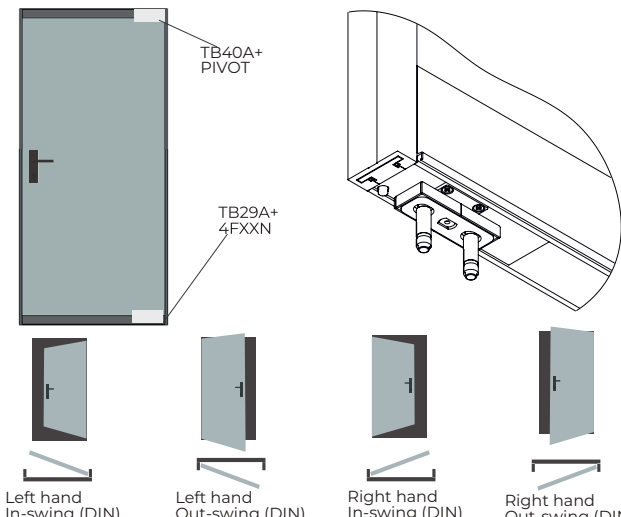

TB40A+ PIVOT

TB29A+ 4FXXN

Left hand In-swing (DIN)   Left hand Out-swing (DIN)   Right hand In-swing (DIN)   Right hand Out-swing (DIN)

**Cerniera idraulica a bilico**

Hydraulic displaced hinge  
Bisagra hidráulica desplazada

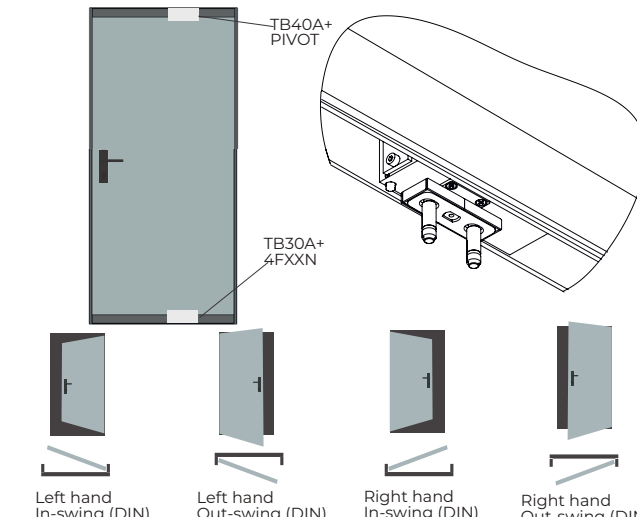

TB40A+ PIVOT

TB30A+ 4FXXN

Left hand In-swing (DIN)   Left hand Out-swing (DIN)   Right hand In-swing (DIN)   Right hand Out-swing (DIN)

**Anta pivotante libera ad angolo**

Door with corner pivot  
Puerta con punto de giro en esquina

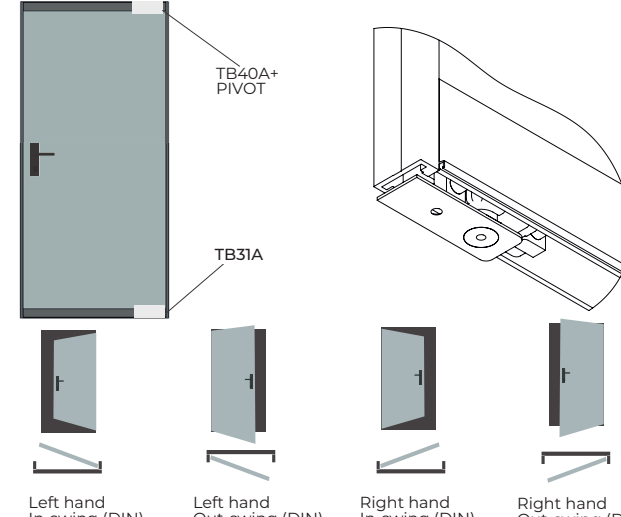

TB40A+ PIVOT

TB31A

Left hand In-swing (DIN)   Left hand Out-swing (DIN)   Right hand In-swing (DIN)   Right hand Out-swing (DIN)

**Anta pivotante libera a bilico**

Door with displaced pivot  
Puerta con punto de giro desplazado

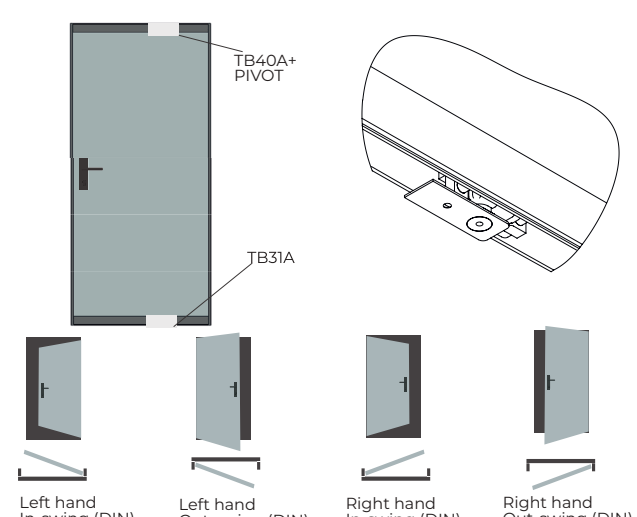

TB40A+ PIVOT

TB31A

Left hand In-swing (DIN)   Left hand Out-swing (DIN)   Right hand In-swing (DIN)   Right hand Out-swing (DIN)

**Anta con chiudiporta RTS**

Door with concealed door closer  
Puerta con cierrapuerta RTS

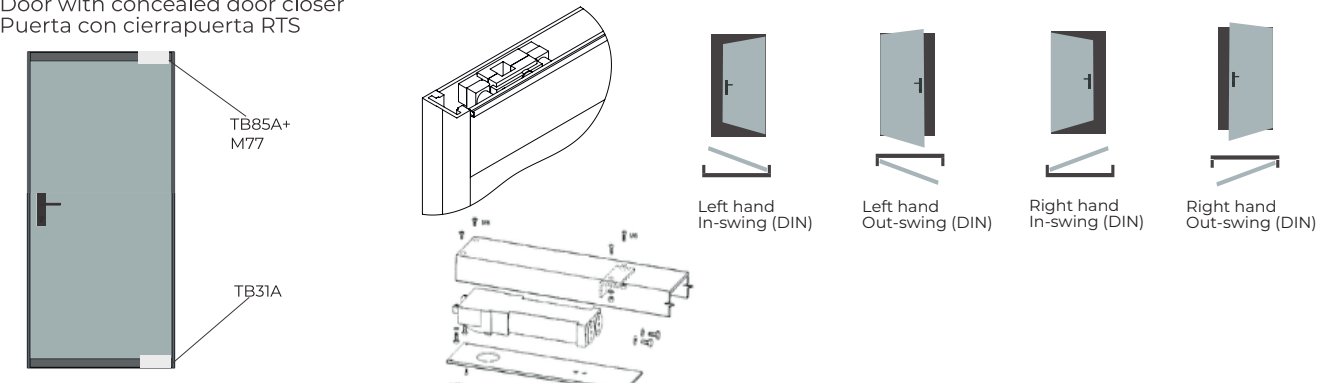

TB85A+ M77

TB31A

Left hand In-swing (DIN)   Left hand Out-swing (DIN)   Right hand In-swing (DIN)   Right hand Out-swing (DIN)

# Configurazioni possibili

Possible configurations | Configuraciones posibles

Profilo porta 1 | Door profile 1 | Perfil puerta 1

## Anta con pivot

Door with pivot | Application on sidelight  
 Puerta con rotación | Instalación con vidrio lateral

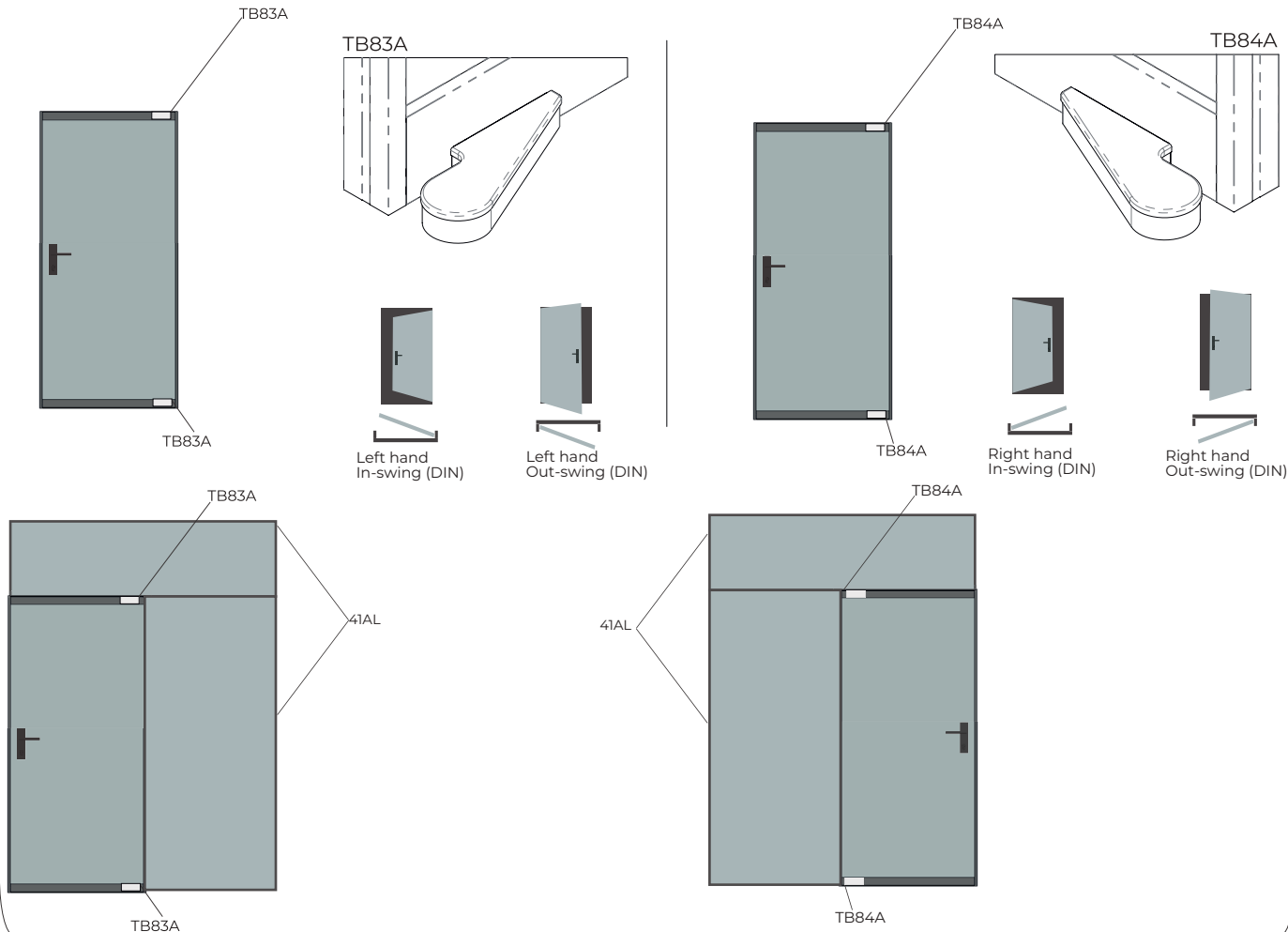

## Anta con chiudiporta a pavimento ad angolo

Door with corner floor spring  
 Puerta con cierrapuerta en esquina

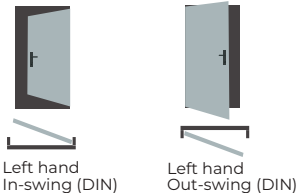
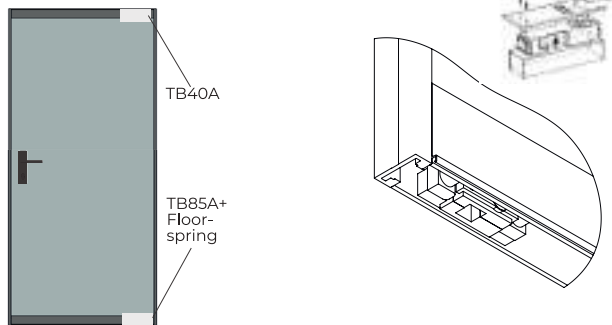

## Anta con chiudiporta a pavimento a bilico

Door with displaced floor spring  
 Puerta con cierrapuerta desplazado

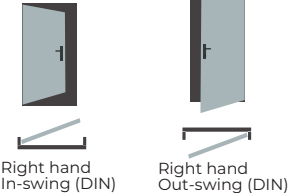
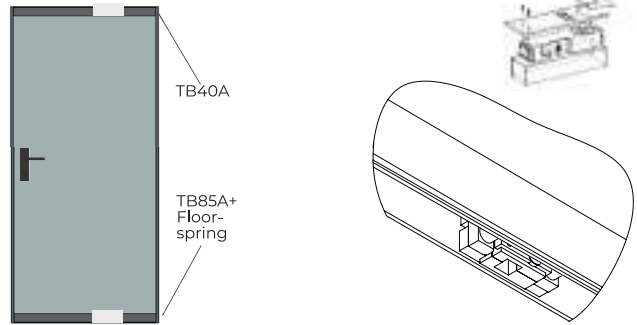

# Profilo porta 1

## Door profile 1 | Perfil puerta 1

Opzione cerniera idraulica o pivot | Sez. tecnica

Option with pivot | Technical section  
Opción con rotación | Sección técnica

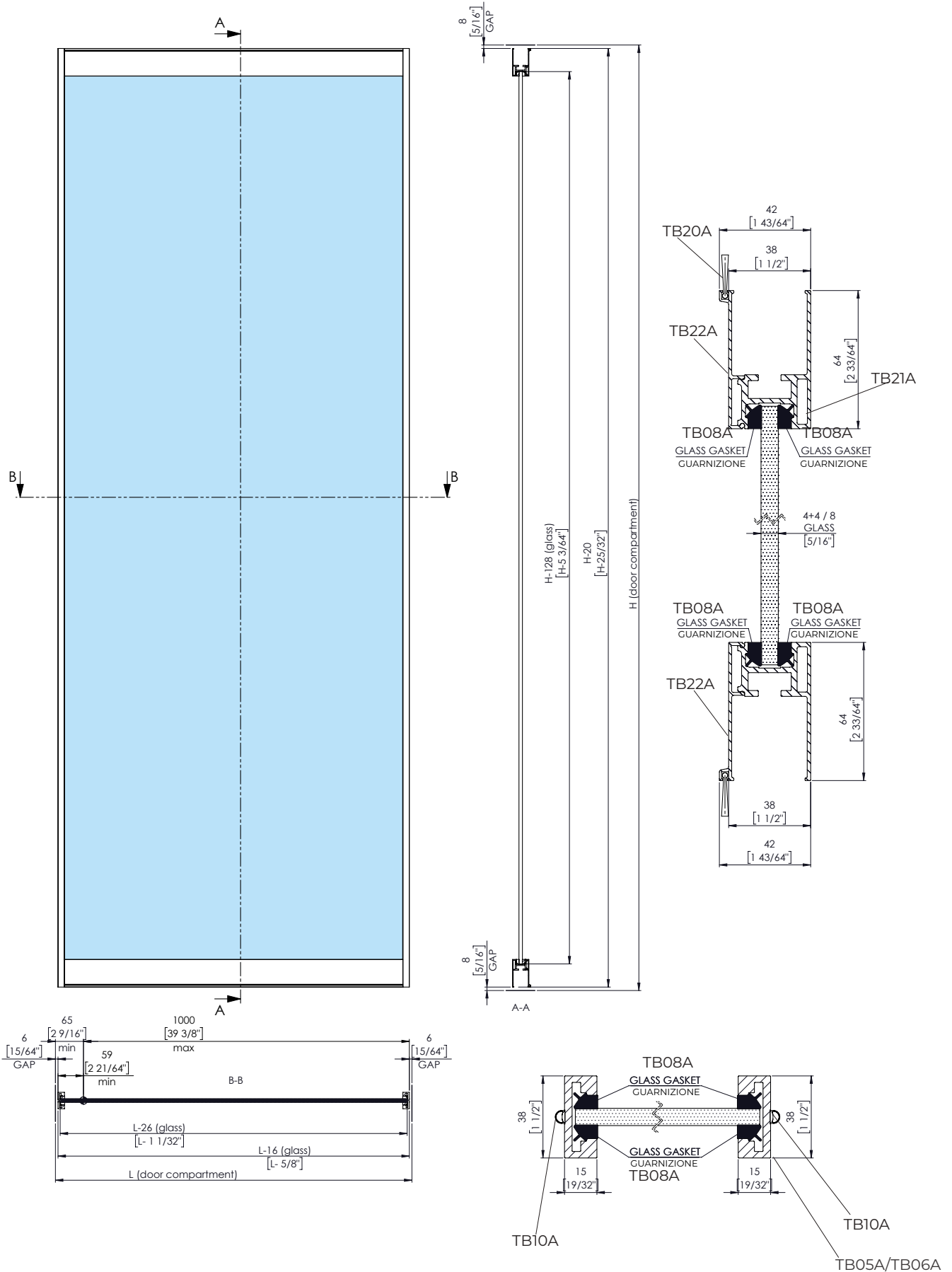

# Profilo porta 1

Door profile 1 | Perfil puerta 1

## Opzione cerniera idraulica o pivottante | Sez. tecnica

Hydraulic option or with pivot | Technical section  
 Opción bisagra hidráulica o rotación | Sección técnica

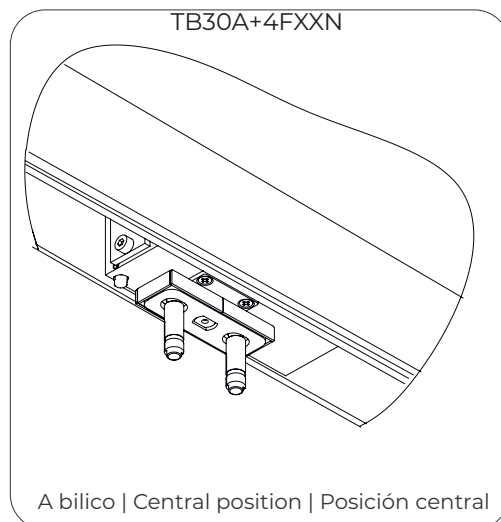
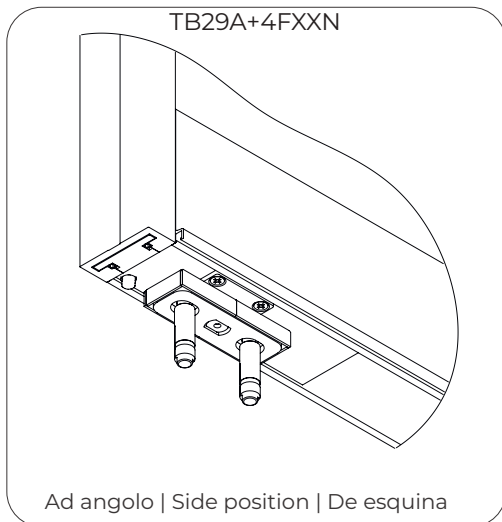

### 4FXXN

Cerniera idraulica per profili  
 Hydraulic hinge for door frames | Bisagra hidráulica para perfiles



Possibile posizione della porta  
 Possible door position  
 Posible posición de la puerta

Chiusura controllata  
 Self-closing  
 Cierre controlado

Posizione libera  
 Free standing  
 Posición libre

● Stop

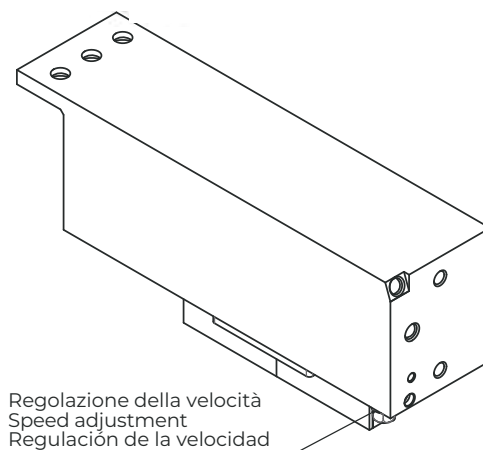
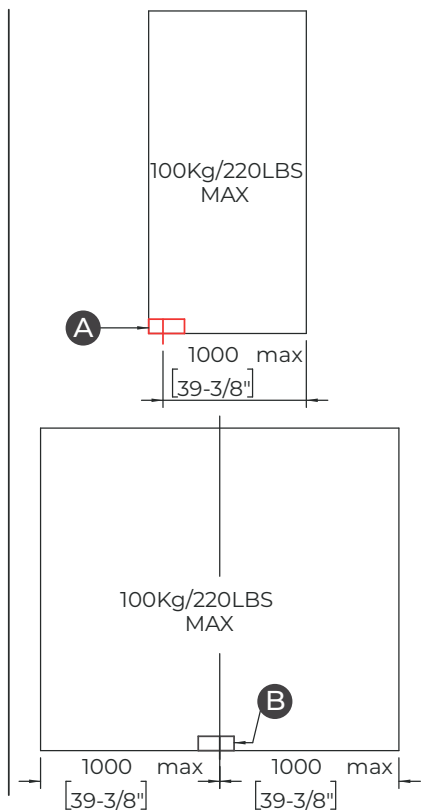
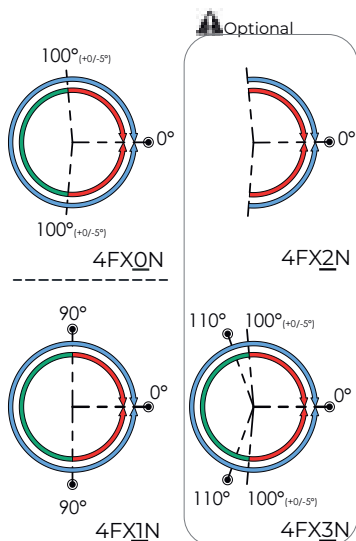

Range di regolazione della posizione  
 Position adjustment range  
 Rango de regulación de la posición

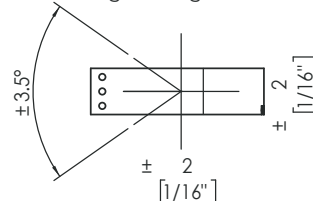

# Profilo porta 1

Door profile 1 | Perfil puerta 1

## Opzione con pivot | Sez. tecnica

With pivot option | Technical section  
Opción con rotación | Sección técnica

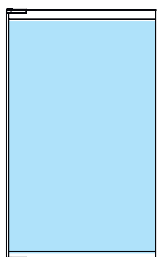

TB83A

Sbalzo sup. e inf. Upper an lower offset pivot  
Rotación superior y inferior con eje desplazado  
**DIN L**

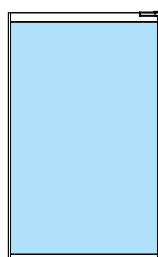

TB84A

Sbalzo sup. e inf. Upper an lower offset pivot  
Rotación superior y inferior con eje desplazado  
**DIN R**

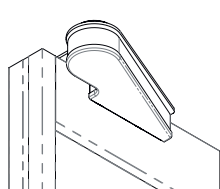

DIN SX

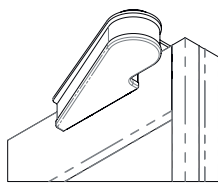

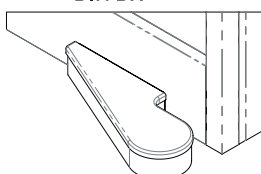
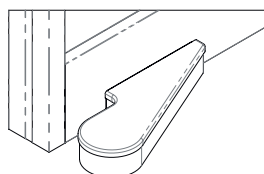

DIN DX

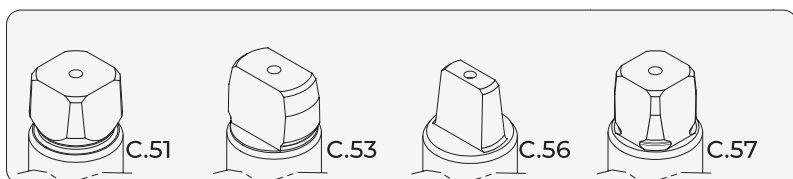

- ✓ Disponibile in versione libera e idraulica (con l'utilizzo di un chiudiporta idraulico).
- ✓ Available in dummy and hydraulic version (with a floorspring or a hydraulic hinge).
- ✓ Disponible en la versión libre o hidráulica (con cierrapuerta o bisagra hidráulica).

 Compatibile con calibri 51, 53 e 57.  
Compliant with calibres 51, 53 and 57.  
Compatible con calibres 51, 53 y 57.



 Compatibile con chiudiporta:  
Compliant with floorsprings:  
Compatible con cierrapuertas:

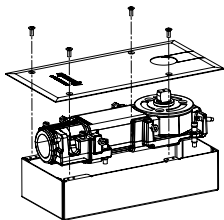

**M25**  
Chiudiporta  
Floor spring  
Cierrapuerta

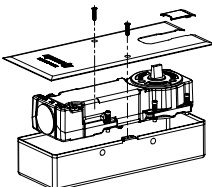

**M60**  
Chiudiporta  
Floor spring  
Cierrapuerta

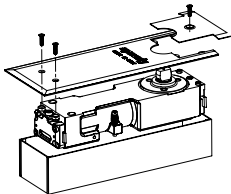

**KS3000**  
Chiudiporta  
Floor spring  
Cierrapuerta

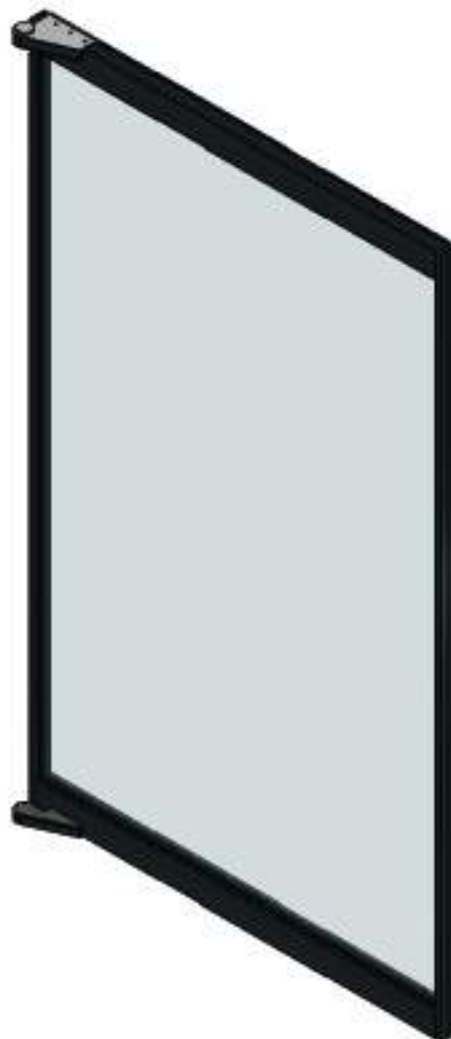

# Profilo porta 1

Door profile 1 | Perfil puerta 1

## Opzione con pivot | Sez. tecnica | Chiudiporta

With pivot option | Technical section | Floor springs  
 Opción con rotación | Sección técnica | Cierrapuertas

### M25

Fermo costante  
 Constant hold open  
 Rotación constante

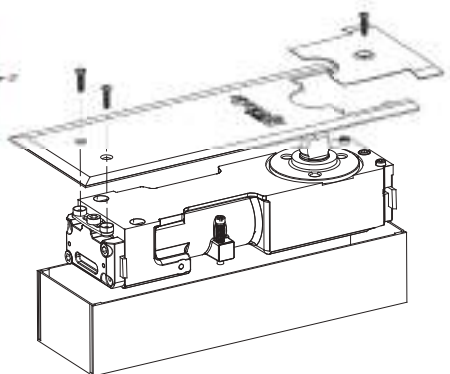
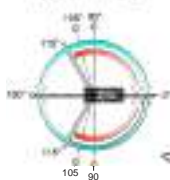

EN 1154 - 3
EN 1154 - 2
EN 1154 - 1
Max.120 Kg
<750
750-850
850-1100

### M60

Fermo costante  
 Constant hold open  
 Rotación constante

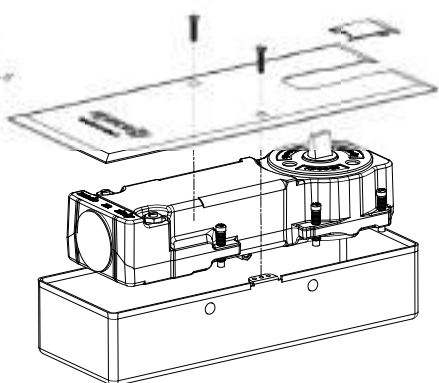
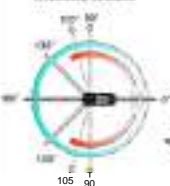

EN 1154 - 3
EN 1154 - 2
EN 1154 - 1
Max.160 Kg
<750
750-1000
950-1150

### KS3000

Fermo costante  
 Constant hold open  
 Rotación constante

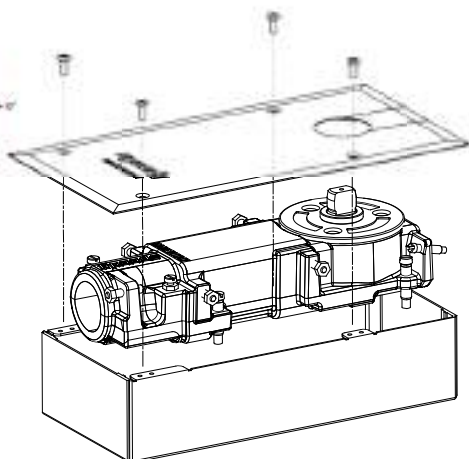
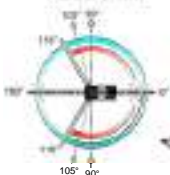

EN 1154 - 4
Max. 200 Kg
EN 1154 - 3
EN 1154 - 2
EN 1154 - 1
Max. 120 Kg
<750
750-850
850-1100
1100-1400

# Profilo porta 2

Door profile 1 | Perfil puerta 2

## Opzione anta a sbalzo in battuta | Sez. tecnica

Offset option | Technical section  
Opción puerta con eje desplazado | Sección técnica

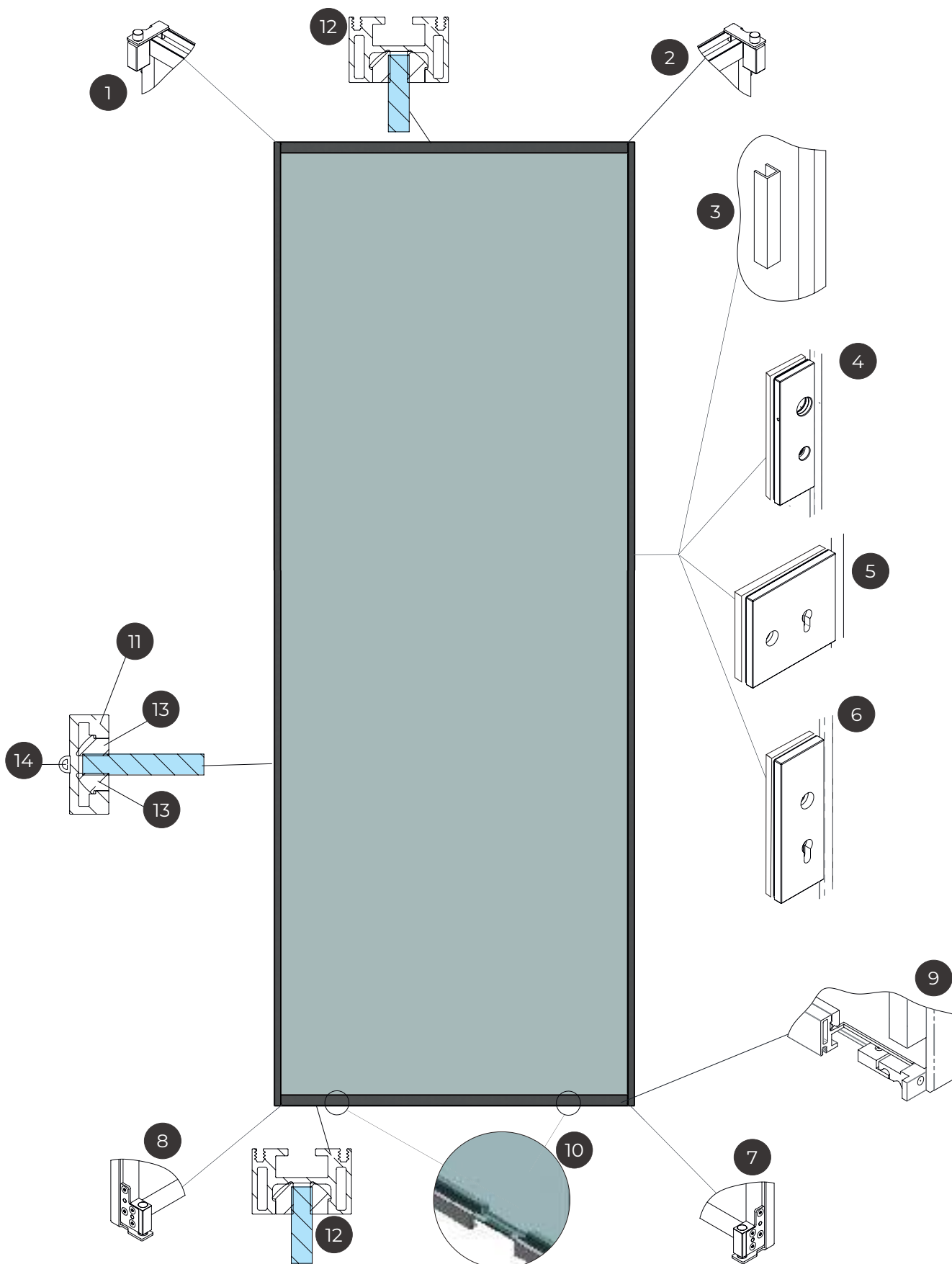

# Profilo porta 2

## Door profile 2 | Perfil puerta 2

### Opzione anta a sbalzo in battuta | Sez. tecnica

Offset option | Technical section  
 Opción puerta con eje desplazado | Sección técnica

**1** **TB47A** **DIN SX** **TB49A\***  
 Pivot ad asse spostato superiore  
 Upper offset pivot  
 Rotación superior con eje desplazado  
 Perno di rotazione sup.  
 Upper pivot  
 Rotación superior

**2** **TB46A** **DIN DX** **TB49A\***  
 Pivot ad asse spostato superiore  
 Upper offset pivot  
 Rotación superior con eje desplazado  
 Perno di rotazione sup.  
 Upper pivot  
 Rotación superior  
 \*Compatibile con serratura elettrica  
 Compatible with electric lock  
 Compatible con cerradura electrónica

**3** **TB43A**  
 Coppia di maniglie a incollare  
 Pair of handles to be glued  
 Par de manetas para pegar

**4** **TB37A** **TBA7A**  
 Serratura verticale US  
 US Vertical lock  
 Cerradura vertical US  
 ⓘ Disponibile con funzione  
 Functions F01, F12, F21, F31 ANSI BAMA 156.13-2017

**5** **TB39A** **TBA9A**  
 Serratura orizzontale EU  
 EU Horizontal lock  
 Cerradura horizontal EU

**6** **TB38A** **TBA8A**  
 Serratura verticale EU  
 EU Vertical lock  
 Cerradura vertical EU

**7** **TB44A**  
 Rotazione inferiore ad asse spostato  
 Offset pivot  
 Rotación inferior con eje desplazado

**8** **TB45A**  
 Serratura verticale EU  
 EU Vertical lock  
 Cerradura vertical EU

**9** **TB16A**  
 Kit 4 angoli telaio  
 4 Corner door frame kit  
 Kit 4 esquinas marco de puerta

**10** **TB19A**  
 Coppia di spessori per supporto vetro  
 Pair of glass supports  
 Par de soportes para vidrio

**11** ⓘ A scelta | To be chosen | A elegir  
**TB20A** **TB09A**  
 Spazzola a infilare  
 Brush gasket for door profile  
 Junta de cepillo  
 Guarnizione tenuta  
 Gasket  
 Junta para insertar

**12** ⓘ A scelta | To be chosen | A elegir  
**TB06A** **TB20A** **TB09A**  
 Montante  
 Door frame  
 Perfil  
 Spazzola a infilare  
 Brush gasket for door profile  
 Junta de cepillo  
 Guarnizione tenuta  
 Gasket  
 Junta para insertar

**13** ⓘ Opzionale | Optional | Opcional  
**TB08A**  
 Guarnizione per ferma-vetro  
 Gasket for glass fixing  
 Junta para vidrio

**14** **TB10A**  
 Guarnizione adesiva di testa  
 Head gasket to be glued  
 Junta a pegar

# Configurazioni possibili

Possible configurations | Configuraciones posibles

## Profilo porta 2 | Door profile 2 | Perfil puerta 2

### Anta a sbalzo in battuta

Offset  
Puerta con eje desplazado

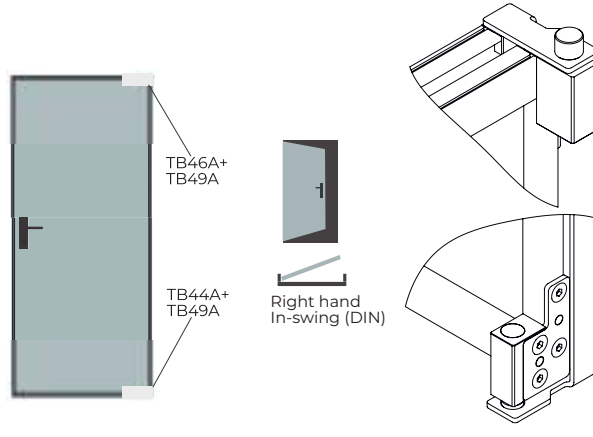
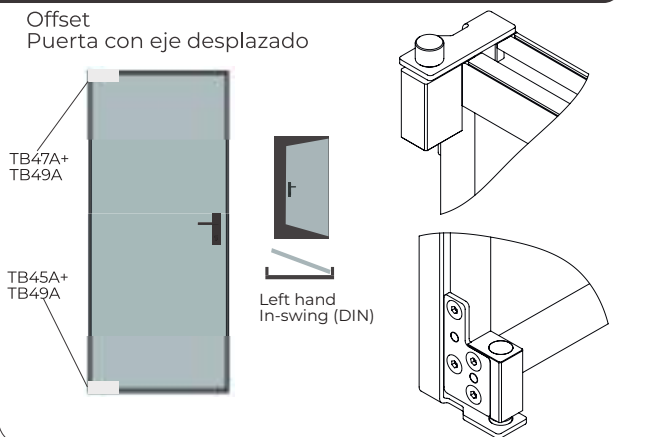

### Anta a sbalzo in battuta | Applicazione su vetro

Offset | Application on sidelight  
Puerta con eje desplazado |  
Instalación con vidrio lateral

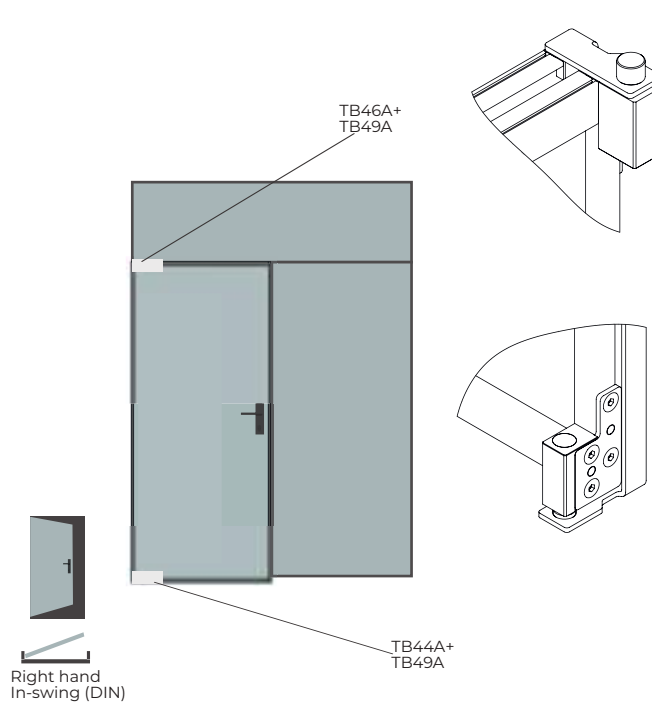
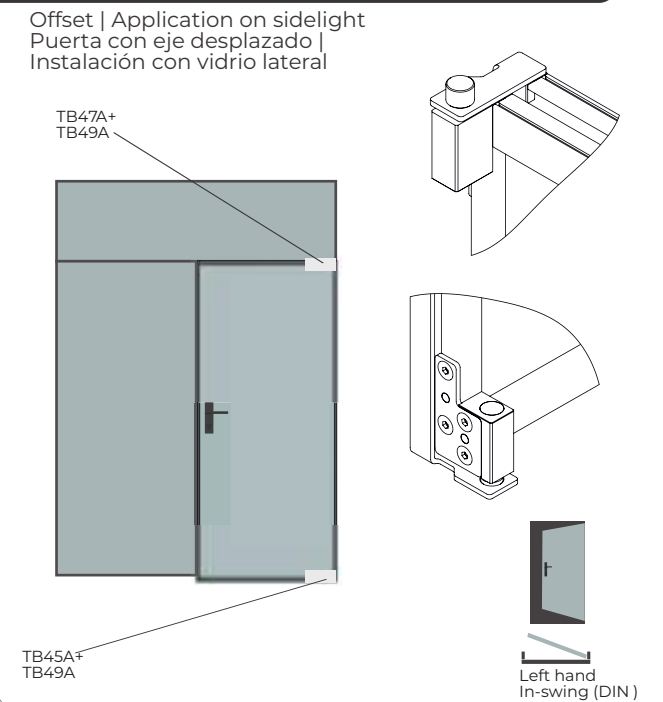

# Profilo porta 2

## Door profile 1 | Perfil puerta 2

### Opzione anta a sbalzo in battuta | Sez. tecnica

Offset option | Technical section  
 Opción puerta con eje desplazado | Sección técnica

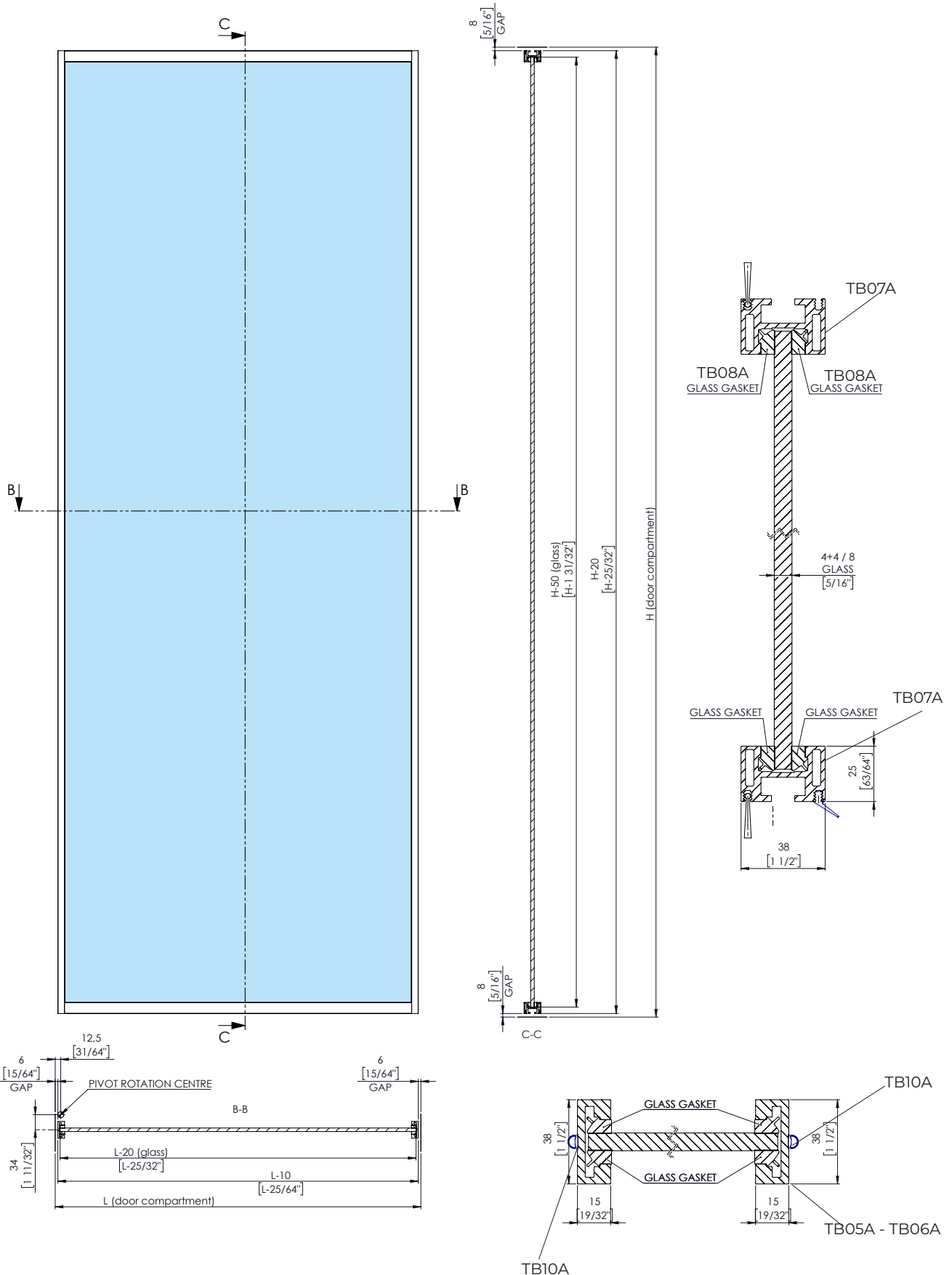

# Profilo porta 2

Door profile 2 | Perfil puerta 2

## Tabula profilo offset+41AL

Sezione tecnica | installazione su vetro

Offset option installation on sidelight | Technical section  
Opción puerta con eje desplazado | Instalación con vidrio lateral | Sección técnica

- i** TB48A Set di viti per il montaggio non incluso (2).
- TB48A Screws KIT not included (2).
- TB48A Juego de tornillos no incluido (2).

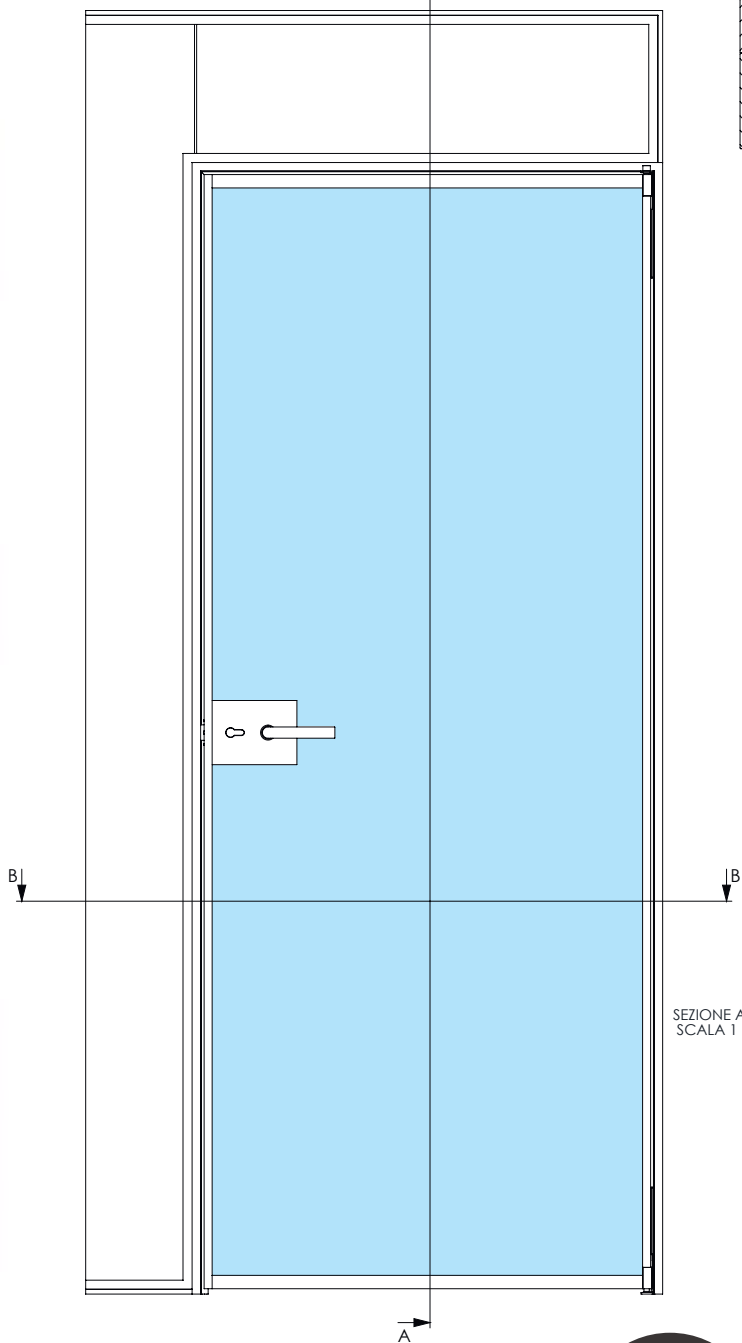
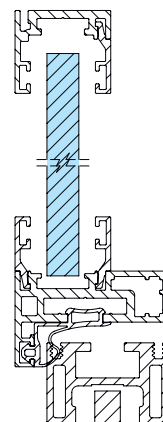
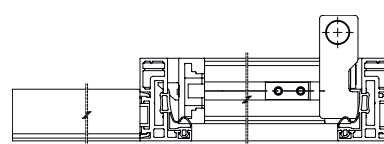
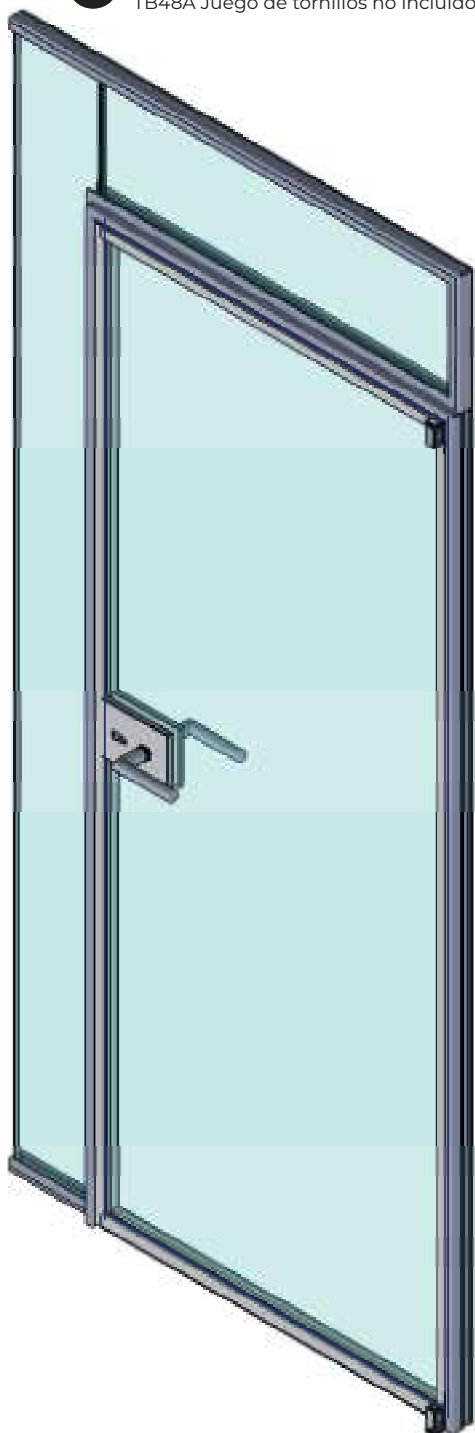

SEZIONE A-A  
SCALA 1 : 1

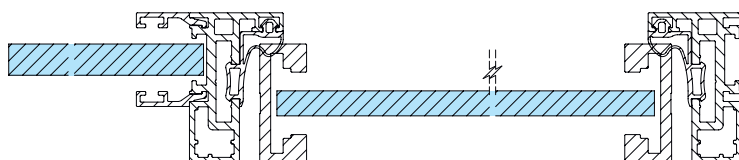

SEZIONE B-B  
SCALA 1 : 1



Noise reduction certification  
Certificación de reducción de ruido

# Serrature e controcattelle

## Patch lock | Cerraduras

### Serratura superiore

Upper key lock system | Cerradura superior

TB34A

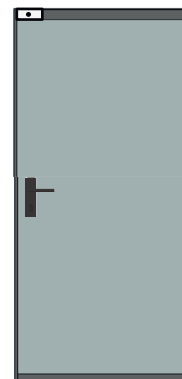
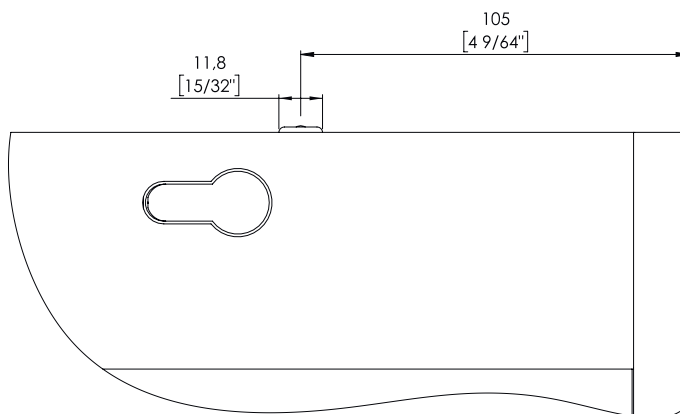
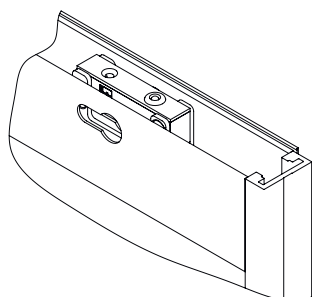

**!** Cilindro consigliato 19133 (non incluso)  
Cylinder suggested 19133 (not included)  
Cilindro aconsejado 19133 (no incluido)

### Serratura inferiore

Lower key lock system | Cerradura inferior

TB34A

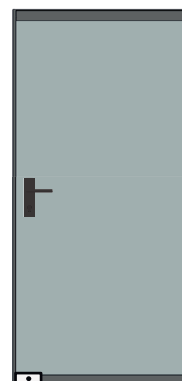
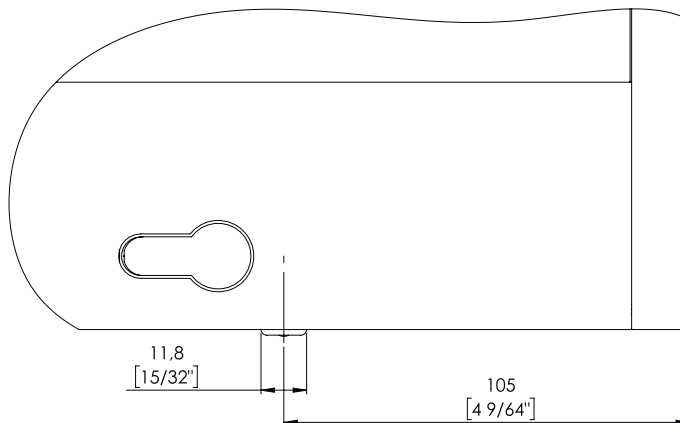
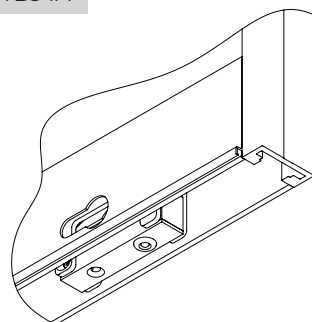

**!** Cilindro consigliato 19133 (non incluso)  
Cylinder suggested 19133 (not included)  
Cilindro aconsejado 19133 (no incluido)

### Cilindri | Cylinders | Cilindros

**!** Non incluso | Not included | No incluido

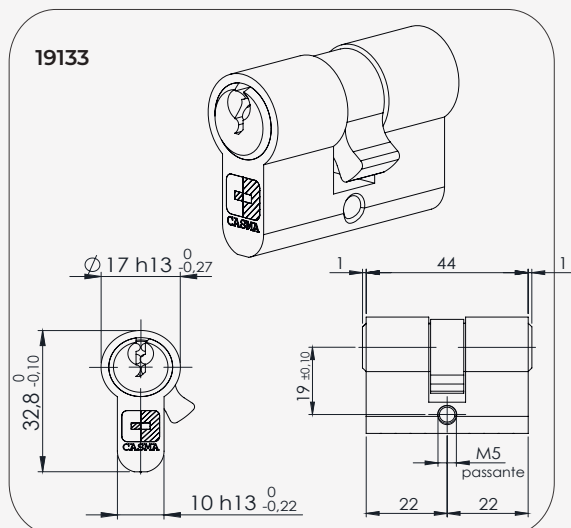

# Serrature e controcattelle

## Patch lock | Cerraduras

### Elettroserratura superiore

Upper electric lock system | Cerradura electrónica superior

**!** Compatibile solo con Profilo porta 1  
Compatible just with Door profile 1  
Compatible solo con Perfil puerta 1

TB35A-TB36A

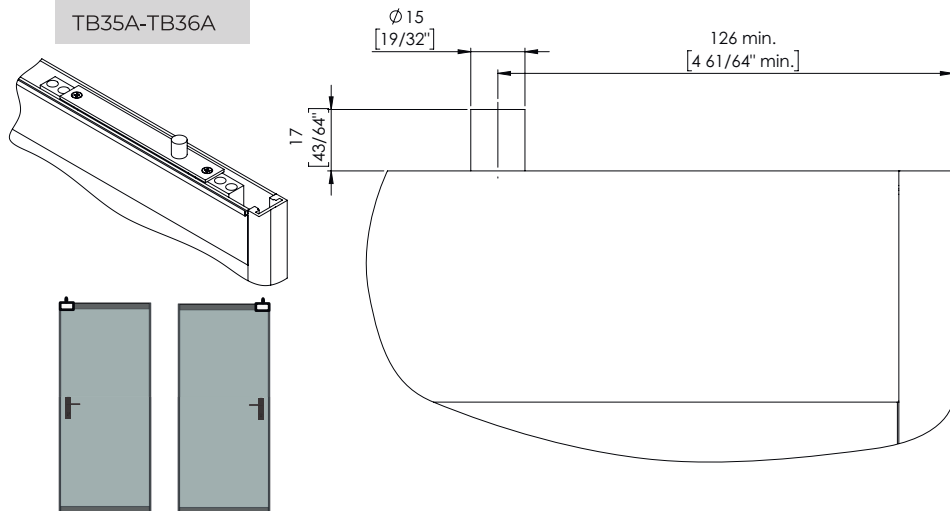

Dimensioni parte mobile Mobile part dimension Dimensión de la parte móvil	192x25x3 mm
Dimensioni corpo Body dimension Dimensión del cuerpo	148x24x34 mm
Alimentazione Power supply Alimentación	12 Vcc 24 Vcc*
Assorbimento di spunto Current consumption Corriente absorbida	820 mA
Assorbimento in stand-by Current consumption in stand-by Corriente absorbida en stand-by	120 mA

\*Opzionale | Optional | Opcional

### Elettropistone

Catenaccio dentro senza corrente

Solenoid bolt | Blocked on open position  
Electropistón | Abierto en ausencia de corriente

TB35A



**!** Il riscontro include placca a soffitto  
Plate on ceiling included  
Placa en el techo incluida

10150

Rotazione superiore per porte con elettropistone  
Upper pivot for doors with solenoid bolt  
Rotación superior para puertas con electropistón

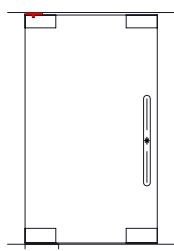
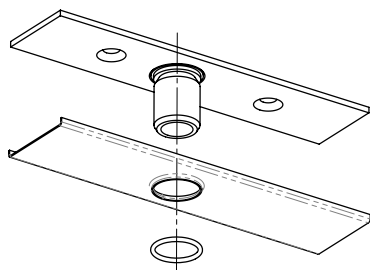

**i** Pulsante o tastierino per apertura a scelta  
Opening button or keypad to choose  
Interruptor o teclado para apertura a elegir

### Elettropistone

Catenaccio fuori senza corrente

Solenoid bolt | Blocked on close position  
Electropistón | Cerrado en ausencia de corriente

TB36A

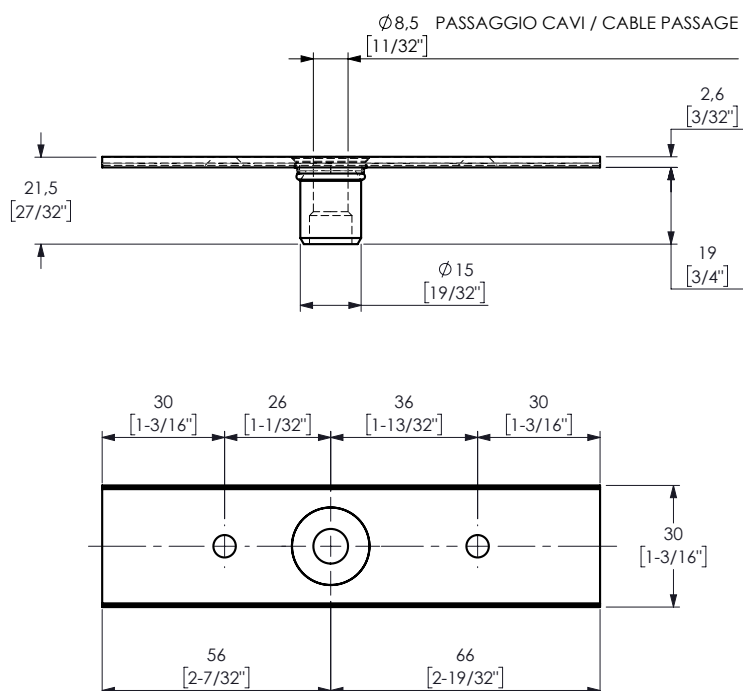

# Serrature e controcartelle

## Locks | Cerraduras

TB38A DIN R  
TBA8A DIN L

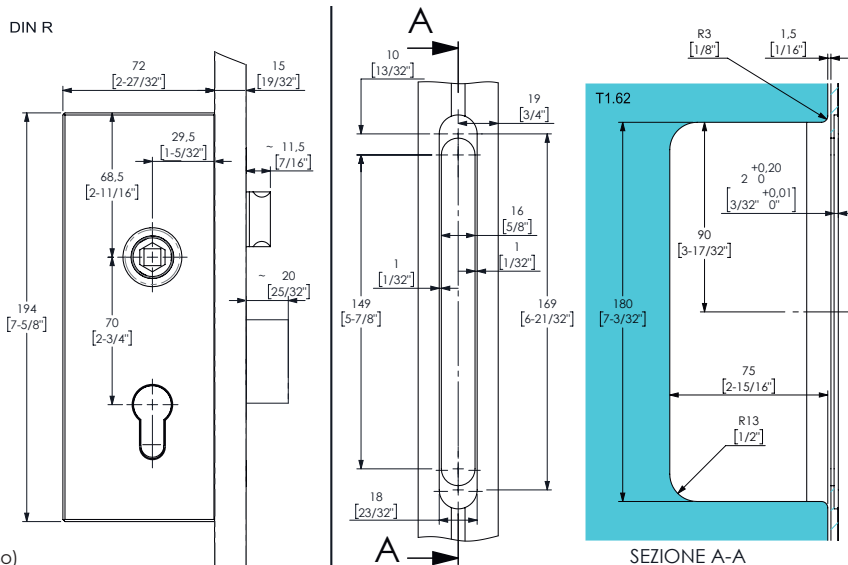
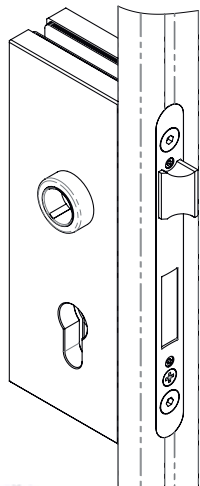

**!** Cilindro consigliato 19133 (non incluso)  
Cylinder suggested 19133 (not included)  
Cilindro aconsejado 19133 (no incluido)

TBC0A DIN R  
TBC1A DIN L

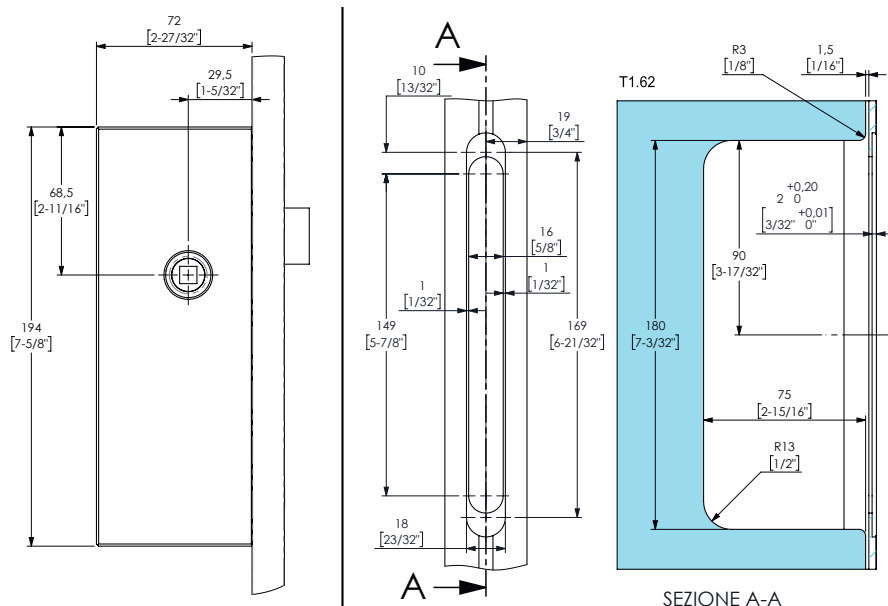
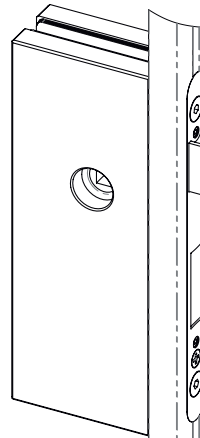

TBB0A DIN R  
TBB1A DIN L

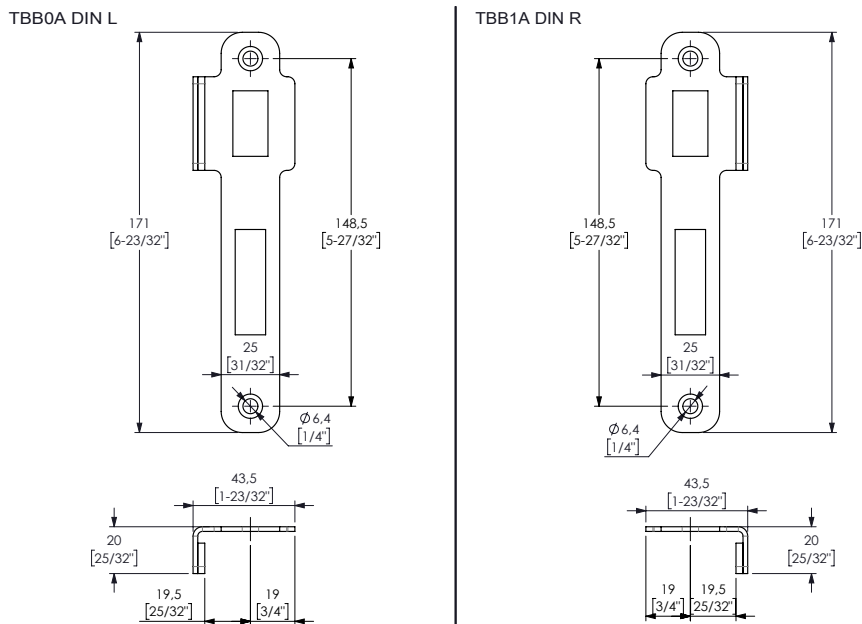
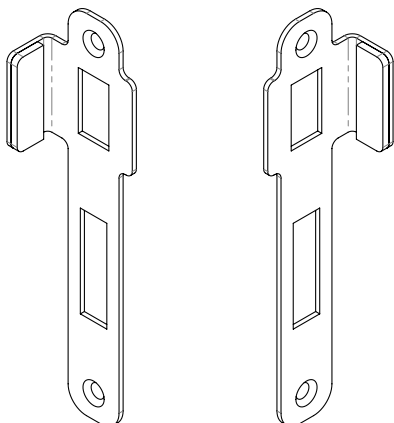

# Serrature e controcartelle

## Patch lock | Cerraduras

### Derecta

TB37A



Disponibile con funzione F01, F12,F21, F31 ANSI BAMA 156.13-2017  
Available with ANSI BAMA 156.13-2017 functions F01, F12,F21, F31

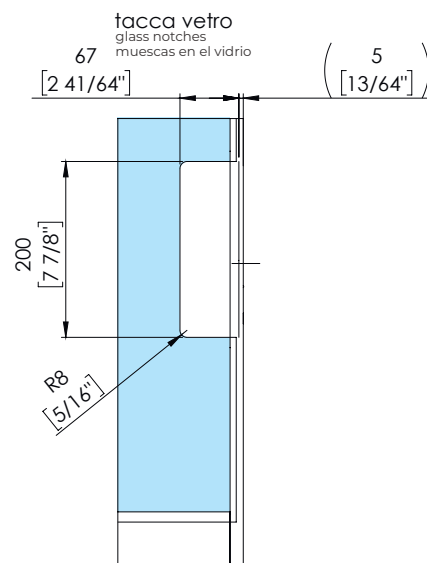
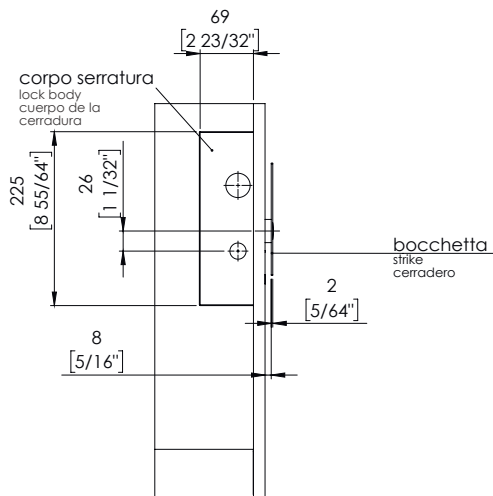
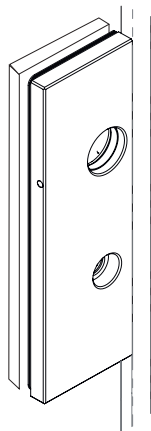

### Quadra

TB39A

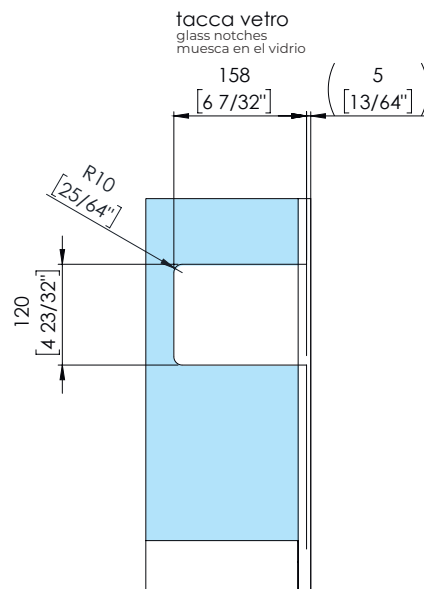
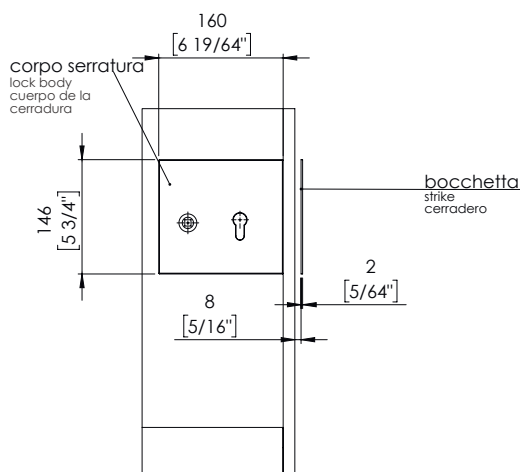
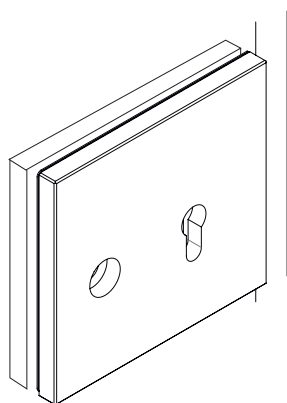

Cilindro consigliato 19133 (non incluso)  
Cylinder suggested 19133 (not included)  
Cilindro aconsejado 19133 (no incluido)

TBA6A DIN R  
TBA8A DIN L

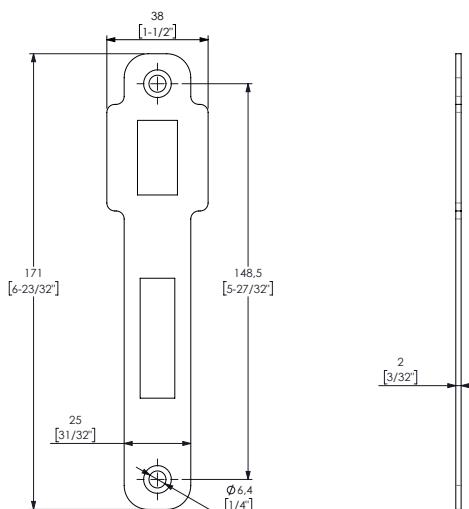
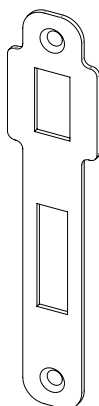

# Serrature e controcartelle

## Locks | Cerraduras

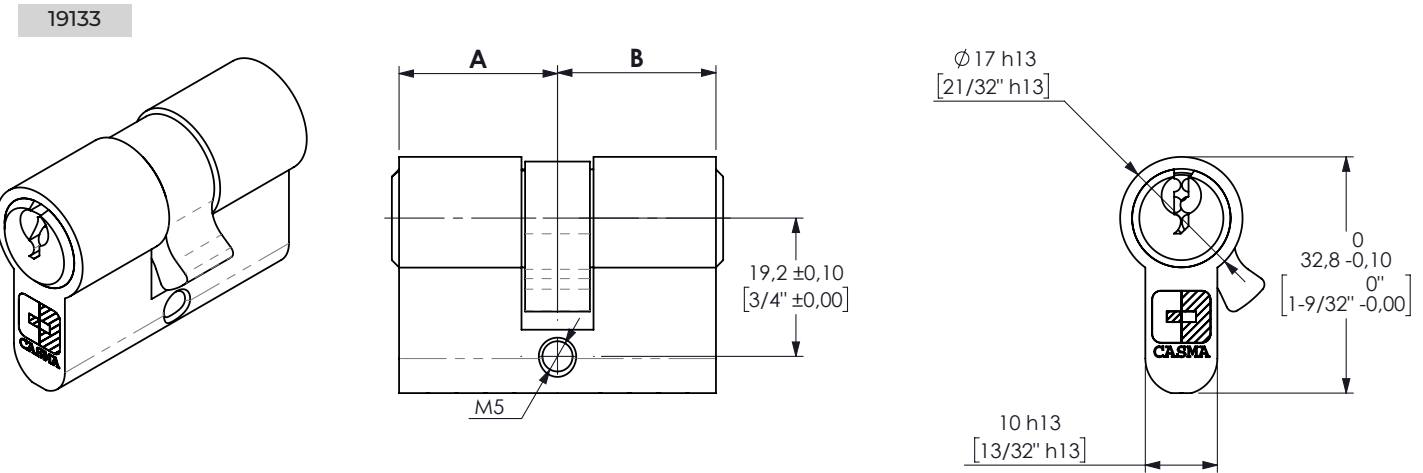
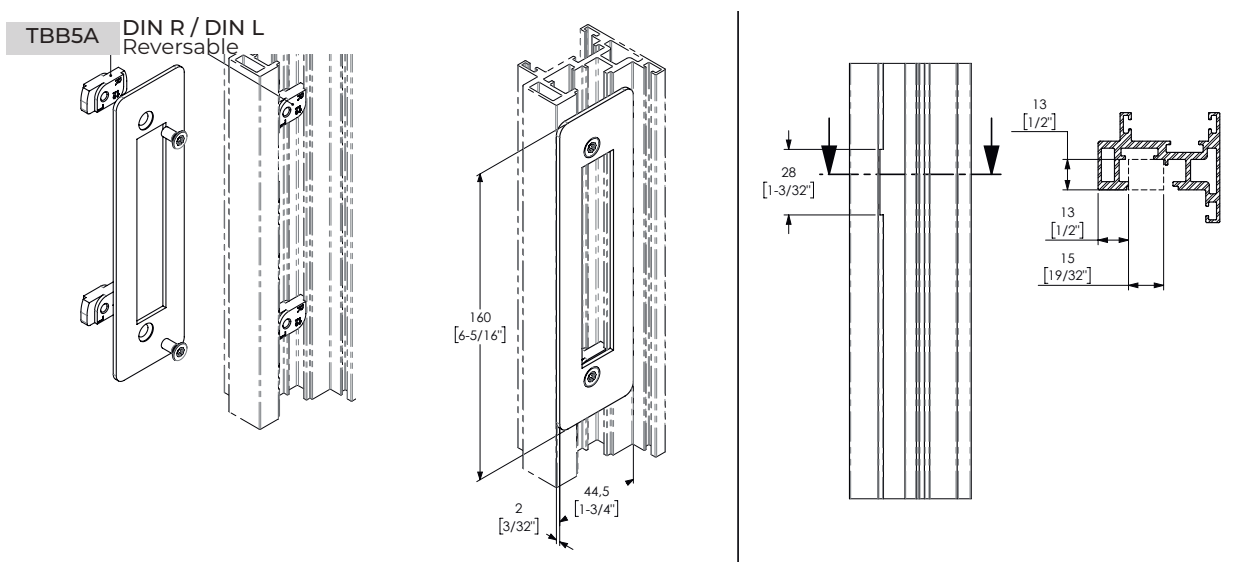
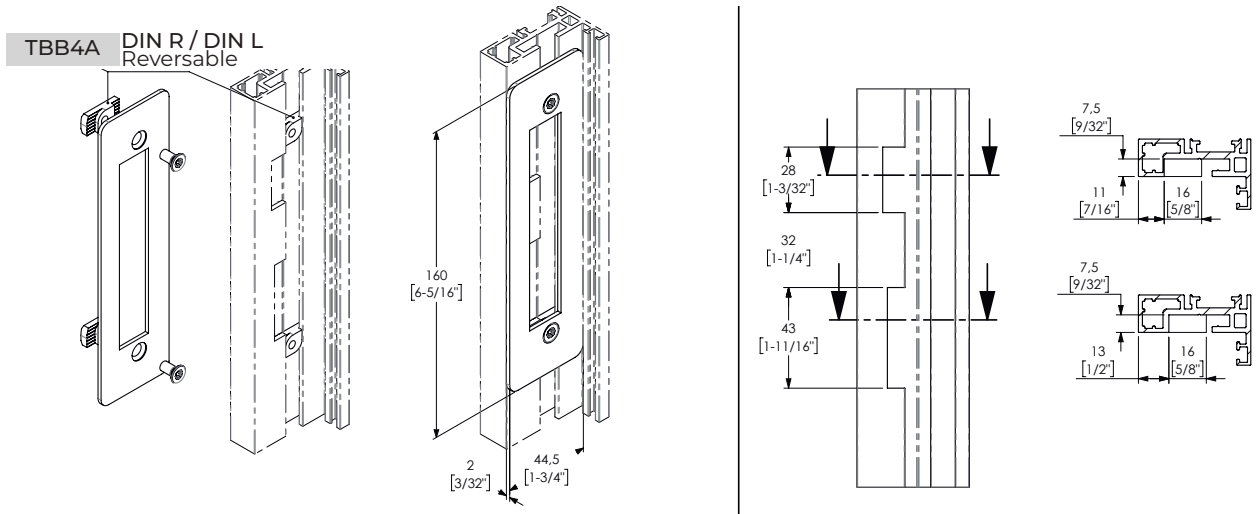

Codice Code Codigo	A		B		Note Notes Notas
<b>19133</b>	22 mm	55/64	22 mm	55/64	solo chiavi miste

# Maniglie

Handles | Manetas

 Non incluso | Not included | No incluido

15607



15609



15610



15611



15612



15613



15614



15623



15625



# Kit

## Kit STANDARD

Profilo porta 1  
Door profile 1  
Perfil puerta 1

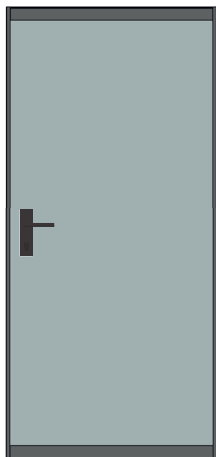

Profilo porta con cerniera idraulica o con rotazione (libera).  
Door profile with hydraulic hinge or pivot.  
Perfil puerta con bisagra hidráulica o con rotación.

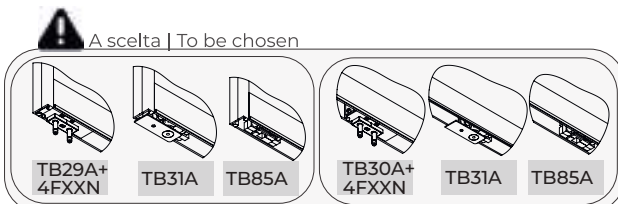
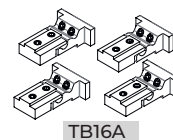
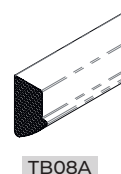
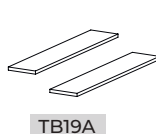
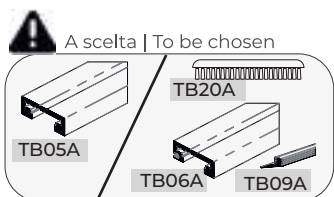
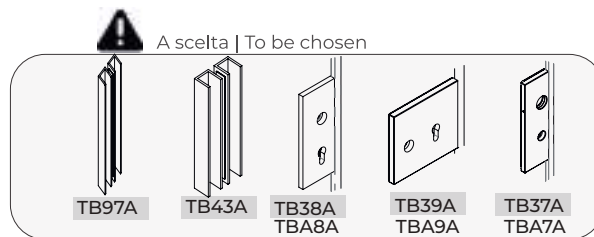
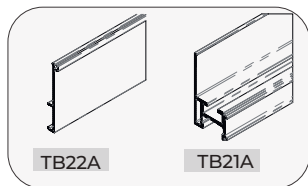

Indicato per applicazioni a vetro. Compatibile con sistema di parete vetrata 41AL  
Suitable for glass installations. Suitable for 41AL frame glass system  
Indicado para aplicaciones a vidrio. Compatible con la pared de vidrio 41AL

Profilo porta 2  
Door profile 2  
Perfil puerta 2

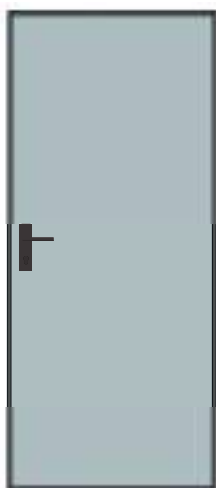

Profilo porta con sbalzo.  
Off set door profile.  
Perfil puerta coneje desplazado.

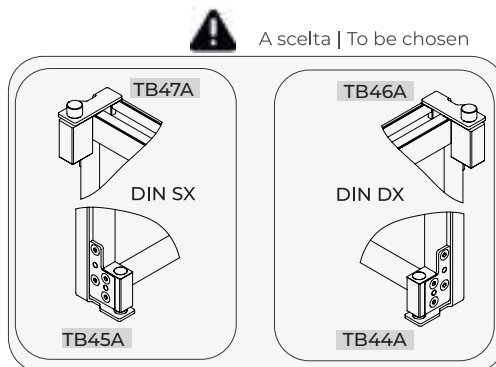
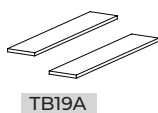
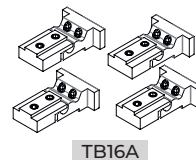
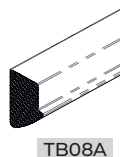
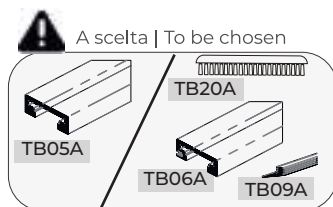
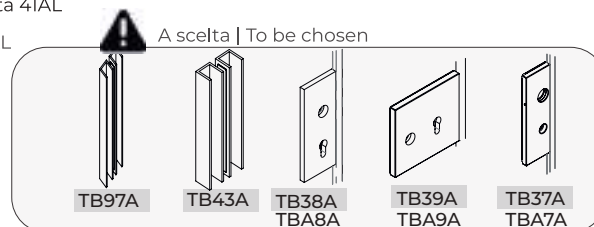
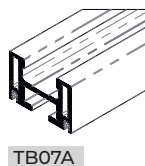

# Kit

## Lock Kit

Profilo porta 1  
Door profile 1  
Perfil puerta 1

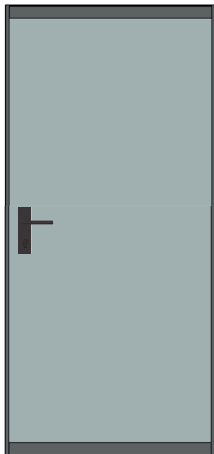

Profilo porta con cerniera idraulica o con rotazione (libera).  
Door profile with hydraulic hinge or pivot.  
Perfil puerta con bisagra hidráulica o con rotación.

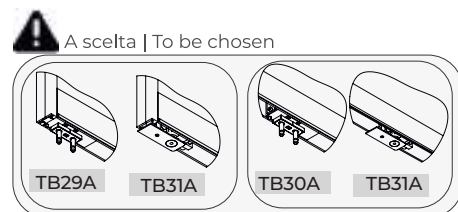
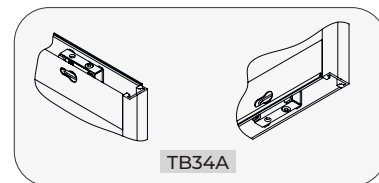
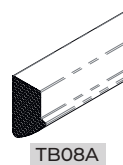
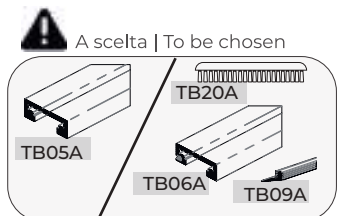
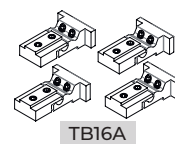
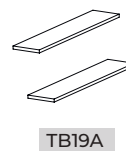
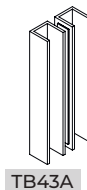
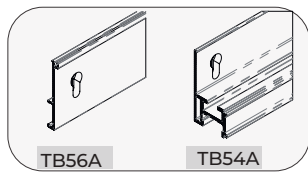

## Kit Electrical

Profilo porta 1  
Door profile 1  
Perfil puerta 1

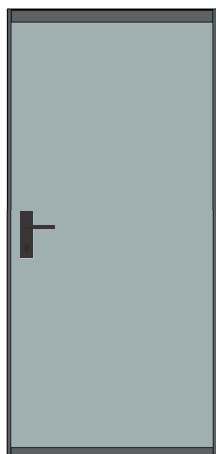

Profilo porta con cerniera idraulica o con rotazione (libera).  
Door profile with hydraulic hinge or pivot.  
Perfil puerta con bisagra hidráulica o con rotación.

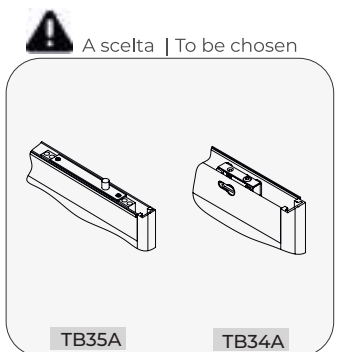
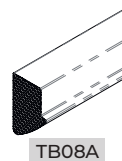
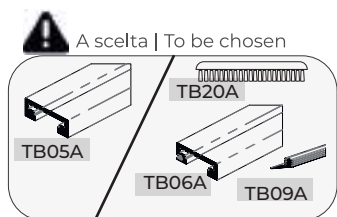
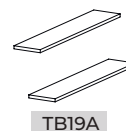
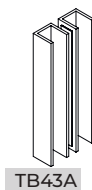
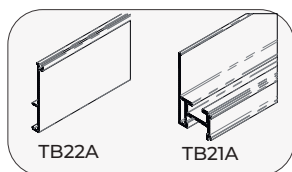

**i** Opzionale | Optional



+

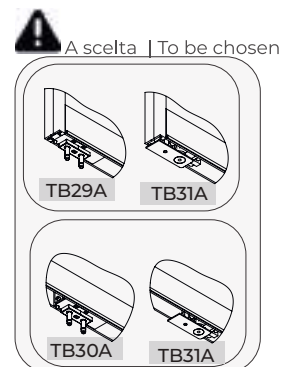
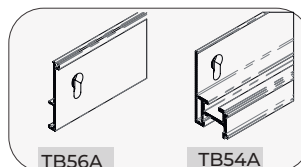

# Kit

## Kit PIVOT

Profilo porta 1  
Door profile 1  
Perfil puerta 1



Profilo porta con pivot  
Door profile with pivot  
Perfil puerta con pivot

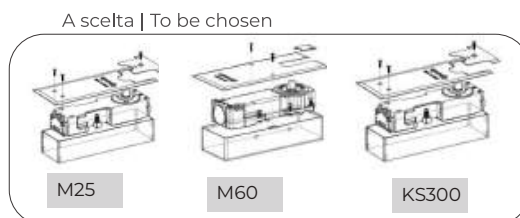
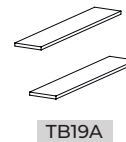
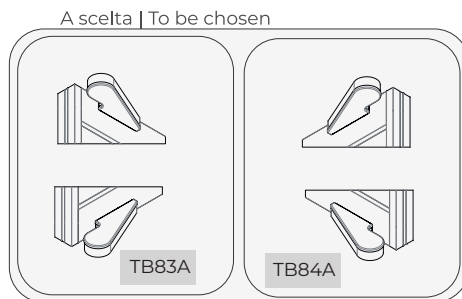
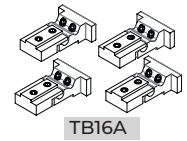
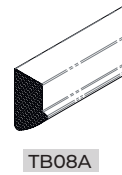
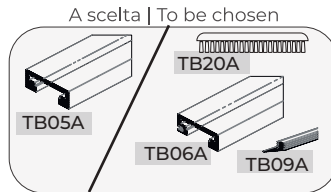
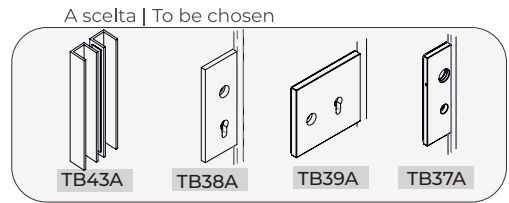
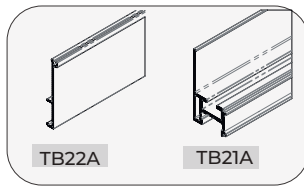

# Componenti

Components | Componentes

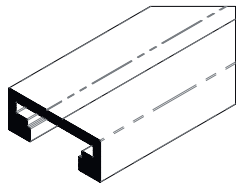

Montante  
Door frame  
Montante



TBO5A		Lunghezza   Length   Longitud
TBO5A 30		3000 mm   118"
TBO5A 60		6000 mm   236"

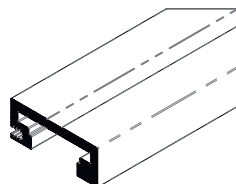

Montante con cava per accessori  
Door frame with accessories groove  
Montante con hueca



TB06A		Lunghezza   Length   Longitud
TB06A 30		3000 mm   118"
TB06A 60		6000 mm   236"

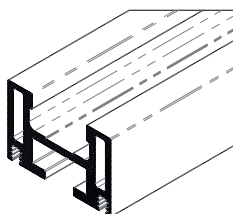

Traversa con cava per accessori  
Traverse with accessories groove  
Traversaño con hueca



TB07A		Lunghezza   Length   Longitud
TB07A 30		3000 mm   118"
TB07A 60		6000 mm   236"

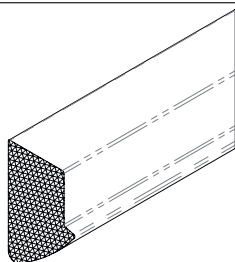

Rotolo di guarnizione ferma-vetro  
Roll of gasket for glass fixing  
Rollo de junta para vidrio



TB08A		Lunghezza   Length   Longitud
TB08A X1		15 m   590"
TB08A X2		25 m   984"
TB08A X3		35 m   1377"

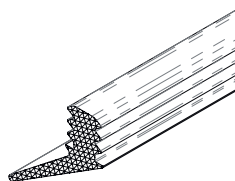

Rotolo guarnizione tenuta  
Roll of gasket  
Rollo de junta para insertar



TB09A		Lunghezza   Length   Longitud
TB09A 60		6000 mm   236"

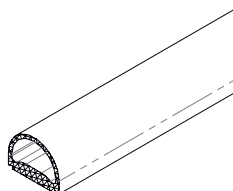

Guarnizione adesiva di testa  
Head gasket to be glued  
Junta a pegar



TB10A		Lunghezza   Length   Longitud
TB10A 60		6000 mm   236"

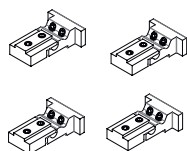











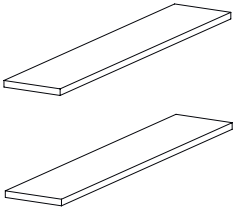

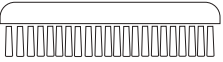

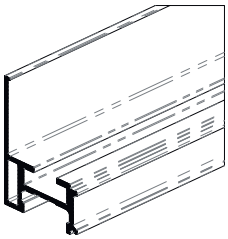
Kit 4 angoli telaio  
4 Corner door frame kit  
Kit 4 esquinas marco de puerta

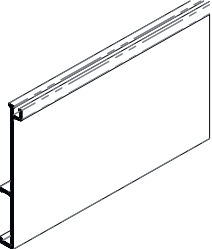

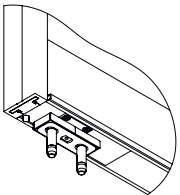

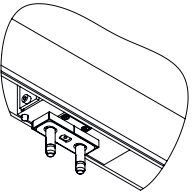

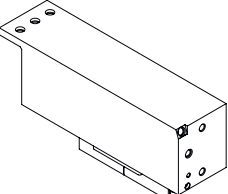





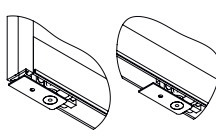

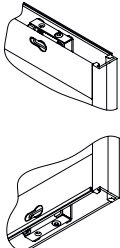



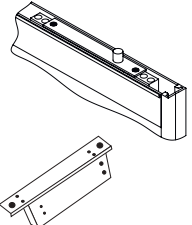



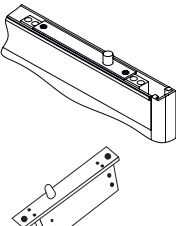



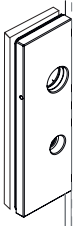

## TB16A

# Componenti

Components | Componentes

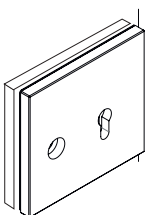
	<p><b>TB19A</b></p> <p>Coppia di spessori per supporto vetro Pair of glass supports Par de soportes para vidrio</p> <p></p>							
	<p><b>TB20A</b></p> <p>Spazzola a infilare Brush gasket for door profile Junta de cepillo</p> <p></p>	<table border="1"> <thead> <tr> <th>TB20A</th> <th>Lunghezza   Length   Longitud</th> </tr> </thead> <tbody> <tr> <td>TB20A 60</td> <td>6000 mm   236"</td> </tr> </tbody> </table>	TB20A	Lunghezza   Length   Longitud	TB20A 60	6000 mm   236"		
TB20A	Lunghezza   Length   Longitud							
TB20A 60	6000 mm   236"							
	<p><b>TB21A</b></p> <p>Traversa Track Traversaño</p> <p></p>	<table border="1"> <thead> <tr> <th>TB21A</th> <th>Lunghezza   Length   Longitud</th> </tr> </thead> <tbody> <tr> <td>TB21A 30</td> <td>3000 mm   118"</td> </tr> <tr> <td>TB21A 60</td> <td>6000 mm   236"</td> </tr> </tbody> </table>	TB21A	Lunghezza   Length   Longitud	TB21A 30	3000 mm   118"	TB21A 60	6000 mm   236"
TB21A	Lunghezza   Length   Longitud							
TB21A 30	3000 mm   118"							
TB21A 60	6000 mm   236"							
	<p><b>TB22A</b></p> <p>Copertina traversa Cover for track Tapa para traversaño</p> <p></p>	<table border="1"> <thead> <tr> <th>TB22A</th> <th>Lunghezza   Length   Longitud</th> </tr> </thead> <tbody> <tr> <td>TB22A 30</td> <td>3000 mm   118"</td> </tr> <tr> <td>TB22A 60</td> <td>6000 mm   236"</td> </tr> </tbody> </table>	TB22A	Lunghezza   Length   Longitud	TB22A 30	3000 mm   118"	TB22A 60	6000 mm   236"
TB22A	Lunghezza   Length   Longitud							
TB22A 30	3000 mm   118"							
TB22A 60	6000 mm   236"							
	<p><b>TB29A</b></p> <p>Kit supporto per cerniera idraulica Frenum ad angolo Corner hydraulic hinge Frenum support kit Kit soporte para bisagra hidráulica Frenum en esquina</p> <p></p>							
	<p><b>TB30A</b></p> <p>Kit supporto per cerniera idraulica Frenum a bilico Displaced hydraulic hinge Frenum support kit Kit soporte para bisagra hidráulica Frenum desplazada</p> <p></p>							
	<p><b>4FXXN</b></p> <p>Cerniera idraulica Frenum 4FXXN Hydraulic hinge Frenum 4FXXN Bisagra hidráulica Fren 4FXXN</p> <p></p>							

# Componenti Components | Componentes

	<p><b>TB31A</b></p> <p>Cerniera pivotante ad angolo o a bilico Bottom corner and displaced pivot Sistema de rotación en esquina y desplazado</p> <p> </p>							
	<p><b>TB34A</b></p> <p>Kit serratura a bilico Displaced lock slot Kit cerradura desplazado</p> <p> </p>	<p> Traversa intestata per serratura TB54A e copertina intestata TB56A non incluse Pre-drilled for lock track TB54A and covee TB56A not included Traversaño preforado para cerradura TB54A y cubierta preforada TB56A no incluidos</p>						
	<p><b>TB35A</b></p> <p>Kit serratura elettrica catenaccio dentro senza corrente Electric lock kit blocked on open position Kit cerradura electrónica abierto en ausencia de corriente</p> <p></p>	<p> Perno di rotazione per serratura elettrica 10150 non incluso Upper pivot for electrical lock 10150 not included Rotación superior para cerradura electrónica 10150 no incluido</p> <p> Il riscontro include placca a soffitto Plate on ceiling included Placa en el techo incluida</p>						
	<p><b>TB36A</b></p> <p>Kit serratura elettrica catenaccio fuori senza corrente Electric lock kit blocked on closed position Kit cerradura electrónica cerrado en ausencia de corriente</p> <p></p>	<p> Perno di rotazione per serratura elettrica 10150 non incluso Upper pivot for electrical lock 10150 not included Rotación superior para cerradura electrónica 10150 no incluido</p> <p> Il riscontro include placca a soffitto Plate on ceiling included Placa en el techo incluida</p>						
	<p>Serratura verticale US US Vertical lock Cerradura vertical</p> <p> </p>	<table border="1"> <thead> <tr> <th>Codice   Code</th> <th>DIN</th> </tr> </thead> <tbody> <tr> <td>TB37A</td> <td>R</td> </tr> <tr> <td>TBA7A</td> <td>L</td> </tr> </tbody> </table> <p> Cilindro non incluso   Cylinder not included   Cilindro nno incluido</p> <p> Disponibile con funzione F01, F12,F21, F31 ANSI BAMA 156.13-2017 Available with ANSI BAMA 156.13-2017 functions F01, F12,F21, F31</p>	Codice   Code	DIN	TB37A	R	TBA7A	L
Codice   Code	DIN							
TB37A	R							
TBA7A	L							
	<p>Serratura verticale EU EU Vertical lock Cerradura vertical EU</p> <p> </p>	<table border="1"> <thead> <tr> <th>Codice   Code</th> <th>DIN</th> </tr> </thead> <tbody> <tr> <td>TB38A</td> <td>R</td> </tr> <tr> <td>TBA8A</td> <td>L</td> </tr> </tbody> </table> <p> Cilindro non incluso   Cylinder not included   Cilindro nno incluido</p>	Codice   Code	DIN	TB38A	R	TBA8A	L
Codice   Code	DIN							
TB38A	R							
TBA8A	L							
	<p>Serratura orizzontale EU EU Horizontal lock Cerradura horizontal EU</p> <p> </p>	<table border="1"> <thead> <tr> <th>Codice   Code</th> <th>DIN</th> </tr> </thead> <tbody> <tr> <td>TB39A</td> <td>R</td> </tr> <tr> <td>TBA9A</td> <td>L</td> </tr> </tbody> </table> <p> Cilindro non incluso   Cylinder not included   Cilindro nno incluido</p>	Codice   Code	DIN	TB39A	R	TBA9A	L
Codice   Code	DIN							
TB39A	R							
TBA9A	L							

# Componenti

Components | Componentes

	<p>Supporto per rotazione superiore ad angolo e a bilico Corner and displaced top pivot slot Soporte para sistema de rotación superior</p>	<p><b>TB40A</b></p>						
	<p>Perno di rotazione superiore Upper pivot Rotación superior</p>	<p><b>10180</b></p>						
	<p>Coppia di maniglie a incollare Pair of handles to be glued Par de manetas para pegar</p>	<table border="1"> <thead> <tr> <th>TB43A</th> <th>Lunghezza   Length   Longitud</th> </tr> </thead> <tbody> <tr> <td>TB43A</td> <td>150 mm   5" 29/32</td> </tr> <tr> <td>TB97A</td> <td>Su richiesta   Upon request   Bajo pedido</td> </tr> </tbody> </table>	TB43A	Lunghezza   Length   Longitud	TB43A	150 mm   5" 29/32	TB97A	Su richiesta   Upon request   Bajo pedido
TB43A	Lunghezza   Length   Longitud							
TB43A	150 mm   5" 29/32							
TB97A	Su richiesta   Upon request   Bajo pedido							
	<p>Rotazione inferiore ad asse spostato Bottom offset pivot Sistema de rotación con eje desplazado</p>	<table border="1"> <thead> <tr> <th>Codice   Code</th> <th>DIN</th> </tr> </thead> <tbody> <tr> <td>TB44A</td> <td>R</td> </tr> </tbody> </table> <p><b>!</b> Per fissaggio su montante porta 41AL necessari TB48A e TB49A (non inclusi) For 41AL door frame fixing required TB48A and TB49A (not included) Para fijajes su perfil puerta 41AL necesita TB48A y TB49A (no incluidos)</p>	Codice   Code	DIN	TB44A	R		
Codice   Code	DIN							
TB44A	R							
	<p>Rotazione inferiore ad asse spostato Bottom offset pivot Sistema de rotación con eje desplazado</p>	<table border="1"> <thead> <tr> <th>Codice   Code</th> <th>DIN</th> </tr> </thead> <tbody> <tr> <td>TB45A</td> <td>L</td> </tr> </tbody> </table> <p><b>!</b> Per fissaggio su montante porta 41AL necessari TB48A e TB49A (non inclusi) For 41AL door frame fixing required TB48A and TB49A (not included) Para fijajes su perfil puerta 41AL necesita TB48A y TB49A (no incluidos)</p>	Codice   Code	DIN	TB45A	L		
Codice   Code	DIN							
TB45A	L							
	<p>Rotazione superiore ad asse spostato Top offset pivot Sistema de rotación con eje desplazado</p>	<table border="1"> <thead> <tr> <th>Codice   Code</th> <th>DIN</th> </tr> </thead> <tbody> <tr> <td>TB46A</td> <td>R</td> </tr> </tbody> </table> <p><b>!</b> Per fissaggio su montante porta 41AL necessari TB48A e TB49A (non inclusi) For 41AL door frame fixing required TB48A and TB49A (not included) Para fijajes su perfil puerta 41AL necesita TB48A y TB49A (no incluidos)</p>	Codice   Code	DIN	TB46A	R		
Codice   Code	DIN							
TB46A	R							
	<p>Rotazione superiore ad asse spostato Top offset pivot Sistema de rotación con eje desplazado</p>	<table border="1"> <thead> <tr> <th>Codice   Code</th> <th>DIN</th> </tr> </thead> <tbody> <tr> <td>TB47A</td> <td>L</td> </tr> </tbody> </table> <p><b>!</b> Per fissaggio su montante porta 41AL necessari TB48A e TB49A (non inclusi) For 41AL door frame fixing required TB48A and TB49A (not included) Para fijajes su perfil puerta 41AL necesita TB48A y TB49A (no incluidos)</p>	Codice   Code	DIN	TB47A	L		
Codice   Code	DIN							
TB47A	L							

# Componenti

Components | Componentes

**TB48A**

Set 5 tasselli per fissaggio su montante porta 41AL  
 Set 5 dowels for 41AL door frame fixing  
 Set 5 tacos para fijación su perfil puerta 41AL

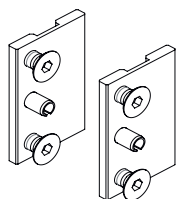

Coppia di piastre supporto per offset pivot  
 Pair of fixing plate for offset pivot  
 Par de placas de fijación para rotación con eje desplazado

**TB49A**



Set 5 tasselli per fissaggio su montante porta 41AL TB48A non incluso  
 Set 5 dowels for 41AL door frame fixing TB48A not included  
 Set 5 tacos para fijación su perfil puerta 41AL TB48A no incluido

**TB54A**



Fondo traversa intestato per serratura  
 Pre-drilled for lock track  
 Traversaño preperforado para cerradura



**TB56A**



Copertina traversa intestata per serratura  
 Pre-drilled for lock track cover  
 Cubierta preforada para cerradura



**TB64A**



Kit Maniglia a incollare per porta battente e copertina contrapposta  
 Kit Handle+opposite cover to be glued for one way door  
 Kit Maneta y cubierta en oposición para pegar para puerta batiente

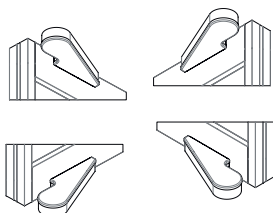

Sbalzo sup. e inf.  
 Upper an lower offset pivot  
 Rotación superior y inferior con eje desplazado



Codice | Code

DIN

TB83A

L

TB84A

R

**TB85A**

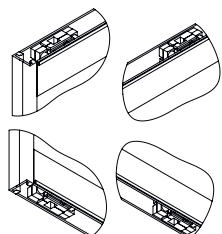

Supporto per pivot RTS inferiore o superiore ad angolo o a bilico  
 Support for displaced or corner, upper or lower RTS  
 Soporte para rotación RTS inferior o superior, desplazado o en esquina









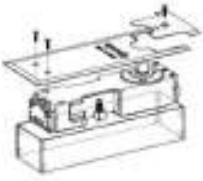
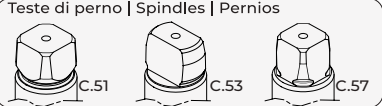
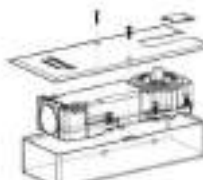
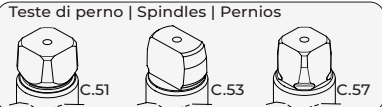
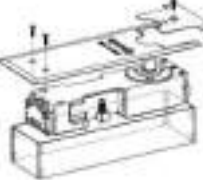
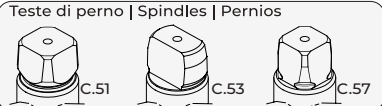
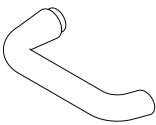

# Componenti

Components | Componentes

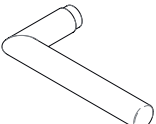
	<p>Bocchetta serratura EU verticale Strike box for vertical lock EU Cerradero para cerradura vertical EU</p>	<p><b>TBA6A</b></p>						
	<p>Bocchetta con battuta serratura verticale EU DIN L/DINR Strike box for vertical lock EU with stop Cerradero para cerradura vertical EU con tope</p>	<table border="1"> <thead> <tr> <th>Codice   Code</th> <th>DIN</th> </tr> </thead> <tbody> <tr> <td>TBB0A</td> <td>L</td> </tr> <tr> <td>TBB1A</td> <td>R</td> </tr> </tbody> </table>	Codice   Code	DIN	TBB0A	L	TBB1A	R
Codice   Code	DIN							
TBB0A	L							
TBB1A	R							
	<p>Kit bocchetta serratura verticale EU per montante porta 41AL Plate for vertical lock for aluminum frame 41AL Kit Kit chapa para cerradura vertical para perfil 41AL</p>	<p><b>TBB4A</b></p>						
	<p>Kit bocchetta serratura verticale EU per montante porta 41AL XL Plate for vertical lock for frame 41AL Chapa para cerradura vertical par perfil 41AL XL</p>	<p><b>TBB5A</b></p>						
	<p>Kit Pomolo fisso + predisposizione maniglia Fixed knob + predisposition for handle Pomo fijo + predisposición manilla</p>	<p><b>TBB9A</b></p>						
	<p>Serratura verticale senza cilindro Vertical lock without cylinder hole Cerradura vertical sin cilindro</p>	<p><b>TBC0A</b></p>						
	<p>Perno di rotazione per serratura elettrica Upper pivot for electrical lock Rotación superior para cerradura electrónica</p>	<p><b>10150</b></p>						

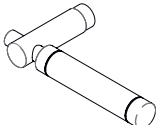

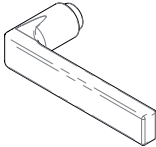







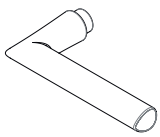

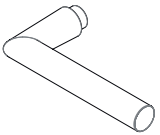
# Componenti

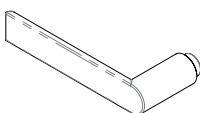
Components | Componentes

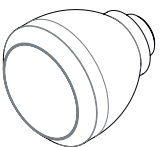
	<p>Chiudiporta a pavimento Floorspring Cierrapuerta</p> <p>Teste di perno   Spindles   Pernios</p> 	<table border="1"> <thead> <tr> <th>M25</th> <th>Forza Strength Fuerza</th> <th>Esterni Exterior Externos</th> <th>Interni Interior Internos</th> </tr> </thead> <tbody> <tr> <td></td> <td><b>Forza gialla</b> Yellow Strength Fuerza amarilla</td> <td><b>75 cm</b> 29 17/32"</td> <td><b>85 cm</b> 33 15/32"</td> </tr> <tr> <td></td> <td><b>Forza rossa</b> Red Strength Fuerza roja</td> <td><b>100 cm</b> 39 3/8"</td> <td><b>110 cm</b> 43 5/16"</td> </tr> <tr> <td></td> <td><b>Forza nera</b> Black Strength Fuerza negra</td> <td><b>110 cm</b> 43 5/16"</td> <td><b>140 cm</b> 55 1/8"</td> </tr> </tbody> </table>	M25	Forza Strength Fuerza	Esterni Exterior Externos	Interni Interior Internos		<b>Forza gialla</b> Yellow Strength Fuerza amarilla	<b>75 cm</b> 29 17/32"	<b>85 cm</b> 33 15/32"		<b>Forza rossa</b> Red Strength Fuerza roja	<b>100 cm</b> 39 3/8"	<b>110 cm</b> 43 5/16"		<b>Forza nera</b> Black Strength Fuerza negra	<b>110 cm</b> 43 5/16"	<b>140 cm</b> 55 1/8"
M25	Forza Strength Fuerza	Esterni Exterior Externos	Interni Interior Internos															
	<b>Forza gialla</b> Yellow Strength Fuerza amarilla	<b>75 cm</b> 29 17/32"	<b>85 cm</b> 33 15/32"															
	<b>Forza rossa</b> Red Strength Fuerza roja	<b>100 cm</b> 39 3/8"	<b>110 cm</b> 43 5/16"															
	<b>Forza nera</b> Black Strength Fuerza negra	<b>110 cm</b> 43 5/16"	<b>140 cm</b> 55 1/8"															
	<p>Chiudiporta a pavimento Floorspring Cierrapuerta</p> <p>Teste di perno   Spindles   Pernios</p> 	<table border="1"> <thead> <tr> <th>M60</th> <th>Forza Strength Fuerza</th> <th>Esterni Exterior Externos</th> <th>Interni Interior Internos</th> </tr> </thead> <tbody> <tr> <td></td> <td><b>Forza gialla</b> Yellow Strength Fuerza amarilla</td> <td><b>75 cm</b> 29 17/32"</td> <td><b>85 cm</b> 33 15/32"</td> </tr> <tr> <td></td> <td><b>Forza rossa</b> Red Strength Fuerza roja</td> <td><b>100 cm</b> 39 3/8"</td> <td><b>110 cm</b> 43 5/16"</td> </tr> </tbody> </table>	M60	Forza Strength Fuerza	Esterni Exterior Externos	Interni Interior Internos		<b>Forza gialla</b> Yellow Strength Fuerza amarilla	<b>75 cm</b> 29 17/32"	<b>85 cm</b> 33 15/32"		<b>Forza rossa</b> Red Strength Fuerza roja	<b>100 cm</b> 39 3/8"	<b>110 cm</b> 43 5/16"				
M60	Forza Strength Fuerza	Esterni Exterior Externos	Interni Interior Internos															
	<b>Forza gialla</b> Yellow Strength Fuerza amarilla	<b>75 cm</b> 29 17/32"	<b>85 cm</b> 33 15/32"															
	<b>Forza rossa</b> Red Strength Fuerza roja	<b>100 cm</b> 39 3/8"	<b>110 cm</b> 43 5/16"															
	<p>Chiudiporta a pavimento Floorspring Cierrapuerta</p> <p>Teste di perno   Spindles   Pernios</p> 	<table border="1"> <thead> <tr> <th>KS3000</th> <th>Forza Strength Fuerza</th> <th>Esterni Exterior Externos</th> <th>Interni Interior Internos</th> </tr> </thead> <tbody> <tr> <td></td> <td><b>Forza gialla</b> Yellow Strength Fuerza amarilla</td> <td><b>75 cm</b> 29 17/32"</td> <td><b>85 cm</b> 33 15/32"</td> </tr> <tr> <td></td> <td><b>Forza rossa</b> Red Strength Fuerza roja</td> <td><b>100 cm</b> 39 3/8"</td> <td><b>110 cm</b> 43 5/16"</td> </tr> </tbody> </table>	KS3000	Forza Strength Fuerza	Esterni Exterior Externos	Interni Interior Internos		<b>Forza gialla</b> Yellow Strength Fuerza amarilla	<b>75 cm</b> 29 17/32"	<b>85 cm</b> 33 15/32"		<b>Forza rossa</b> Red Strength Fuerza roja	<b>100 cm</b> 39 3/8"	<b>110 cm</b> 43 5/16"				
KS3000	Forza Strength Fuerza	Esterni Exterior Externos	Interni Interior Internos															
	<b>Forza gialla</b> Yellow Strength Fuerza amarilla	<b>75 cm</b> 29 17/32"	<b>85 cm</b> 33 15/32"															
	<b>Forza rossa</b> Red Strength Fuerza roja	<b>100 cm</b> 39 3/8"	<b>110 cm</b> 43 5/16"															
	<p>Maniglia Handle Maneta</p> 	<p><b>15607</b></p>																
	<p>Maniglia Handle Maneta</p> 	<p><b>15609</b></p>																
	<p>Maniglia Handle Maneta</p> 	<p><b>15610</b></p>																
	<p>Maniglia Handle Maneta</p> 	<p><b>15611</b></p>																

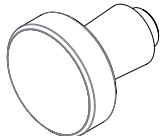
# Componenti

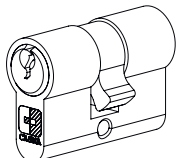
Components | Componentes

	Maniglia Handle Maneta		15612
	Maniglia Handle Maneta		15613
	Maniglia Handle Maneta		15614
	Pomolo Knob Pomo		15623
	Pomolo Knob Pomo		15625
	Cilindro Cylinder Cilindro		19133



WCP7



**Finiture standard  
Standard finishes  
Acabados estándar**

611

Alluminio anodizzato naturale  
Silver anodized aluminum  
Aluminio anodizado natural

620

Alluminio anodizzato nero  
Black anodized aluminum  
Aluminio anodizado negro



**Spessore vetro**  
Glass thickness  
Espesor del vidrio

**10 ÷ 12 mm\***  
25/64" ÷ 5/16"

\*Ulteriori spessori su richiesta  
\*More thicknesses upon request  
\*Más espesores bajo pedido



**Portata**  
Weight  
Peso

**100 kg**  
247,50 Lbs

**Max. altezza anta**  
Max. door width  
Max. altura de la puerta

**3000 mm\***  
118 7/64" \*

\*Ulteriori altezze su richiesta  
\*More heights upon request  
\*Más alturas bajo pedido

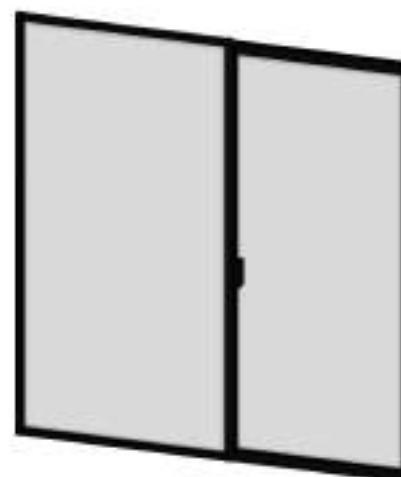
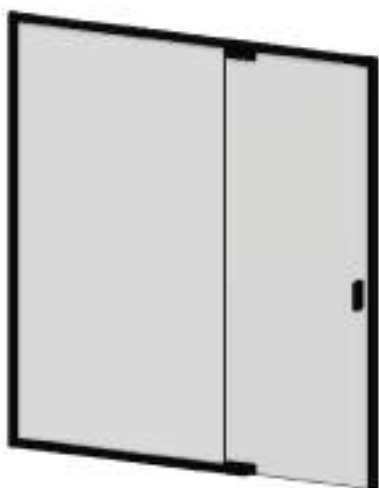

# Profilo 1 Frame 1 | Perfil 1



# Profilo 1 Frame 1 | Perfil 1

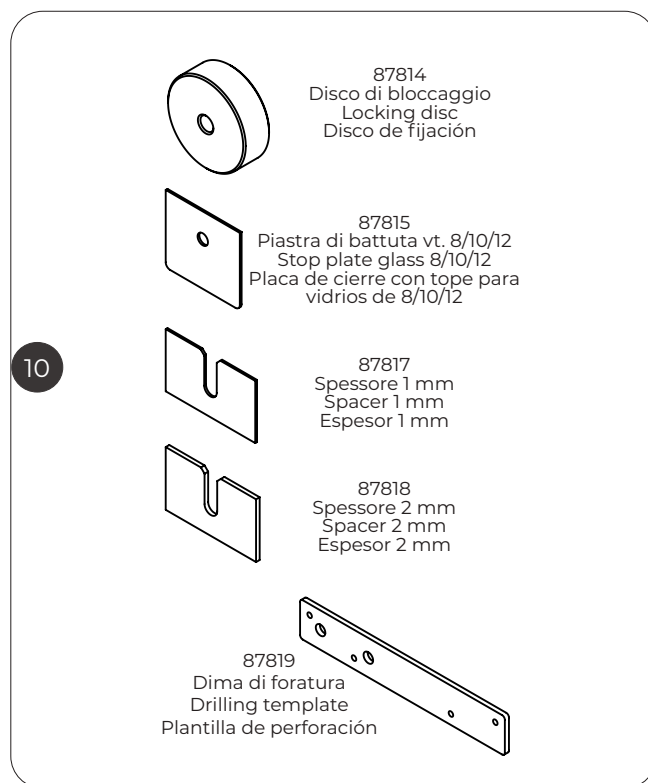
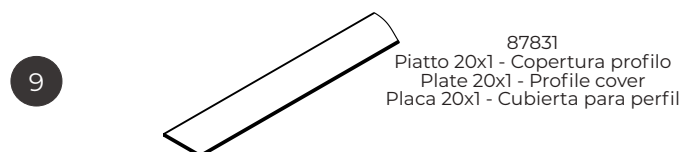
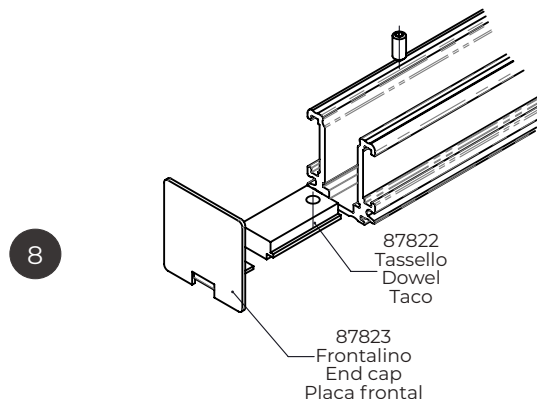
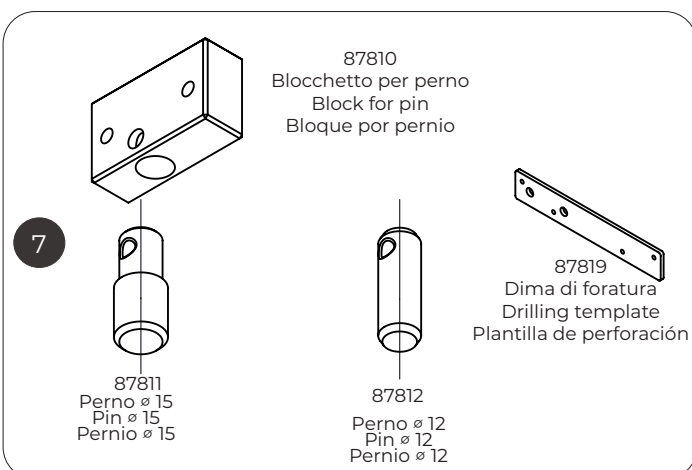
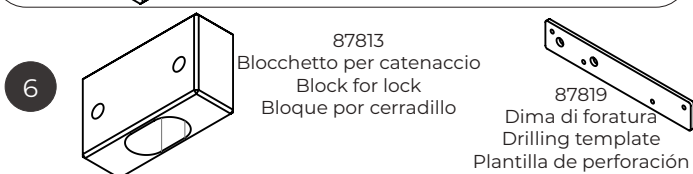
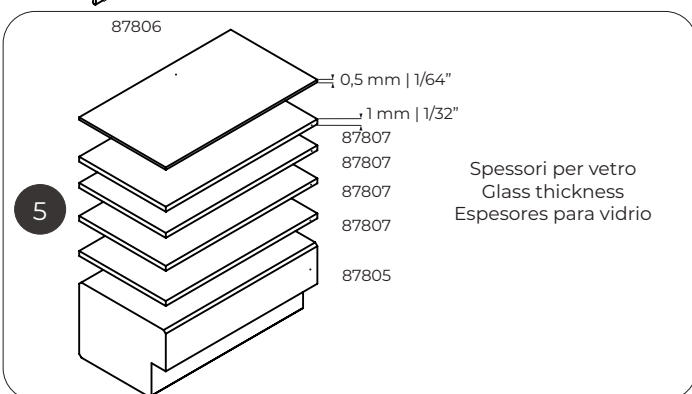
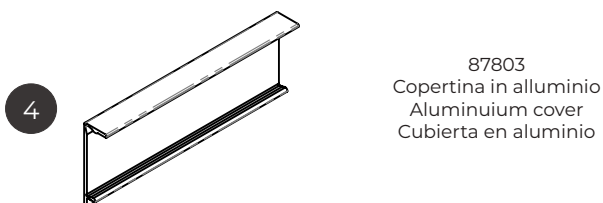
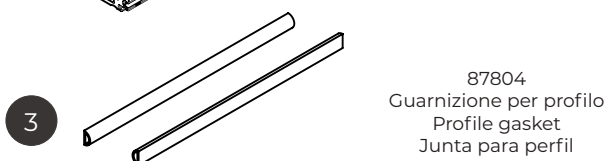
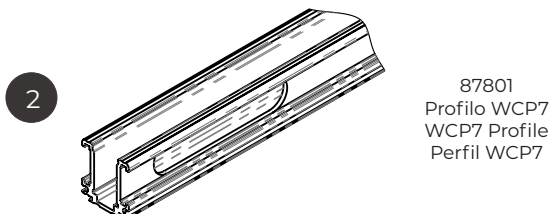
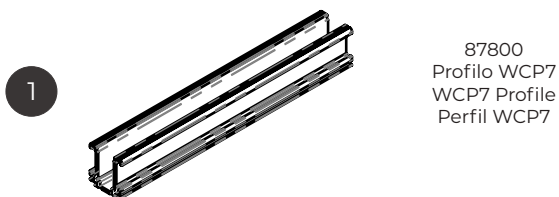

# Profilo 1

Frame 1 | Perfil 1

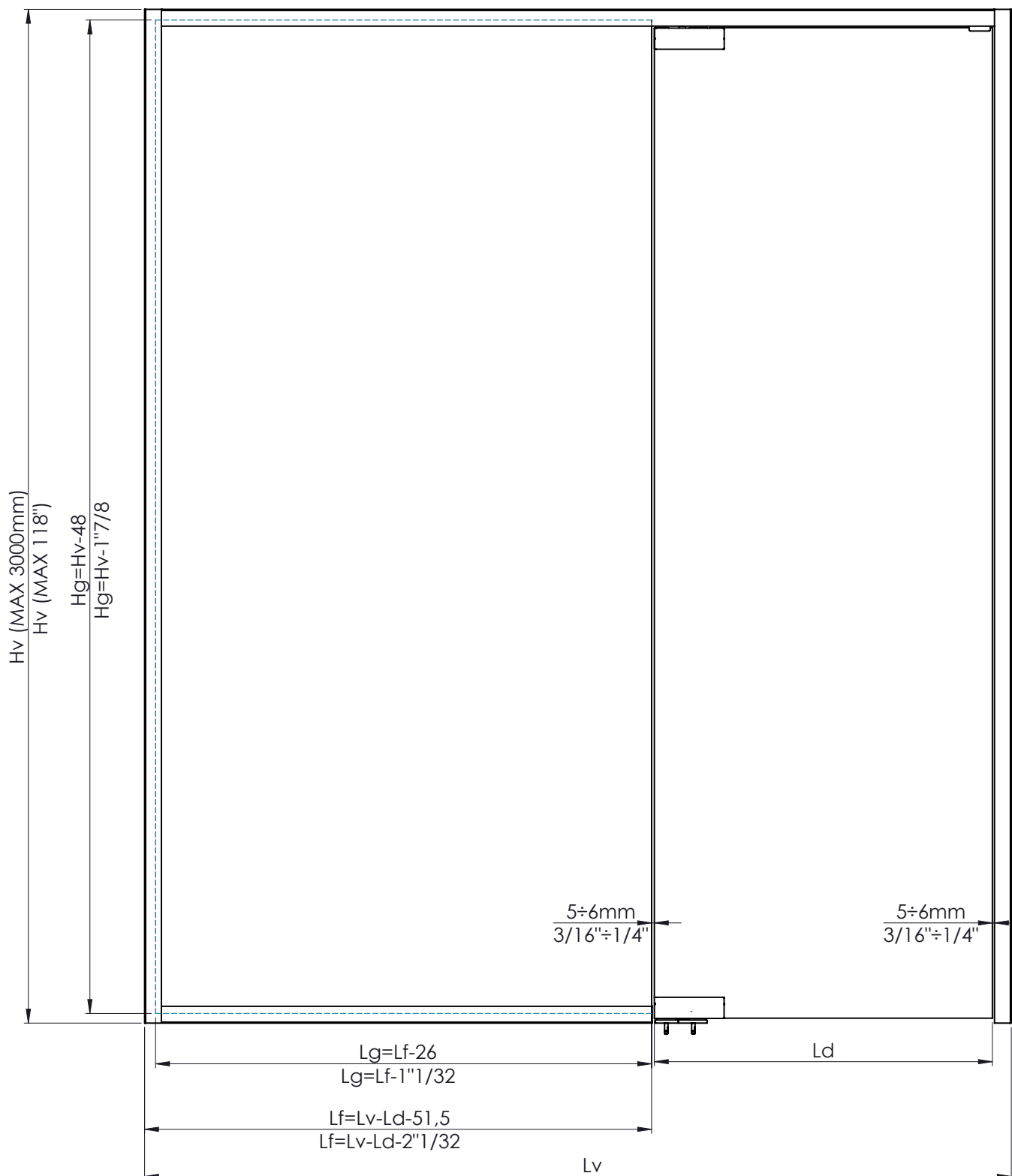

- $H_v$ = Altezza vano | Space height | Altura espacio
- $H_g$ = Altezza vetro fisso | Fixed glass height | Altura vidrio fijo
- $L_v$ = Larghezza vano | Space width | Ancho espacio
- $L_d$ = Larghezza porta | Door width | Ancho puerta
- $L_f$ = Larghezza frame inferiore | Lower frame width | Ancho marco inferior
- $L_g$ = Larghezza vetro fisso | Fixed glass width | Ancho vidrio fijo

# Configurazioni

Configurations | Configuraciones

## Senza frame

Frameless | Sin marco

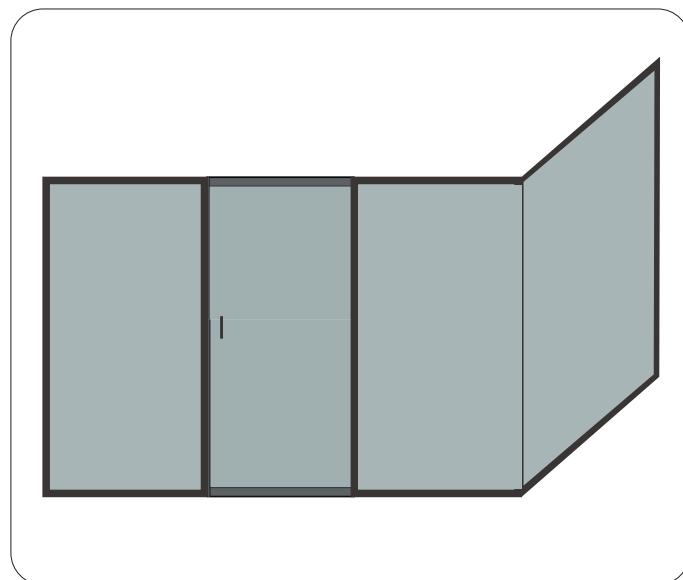
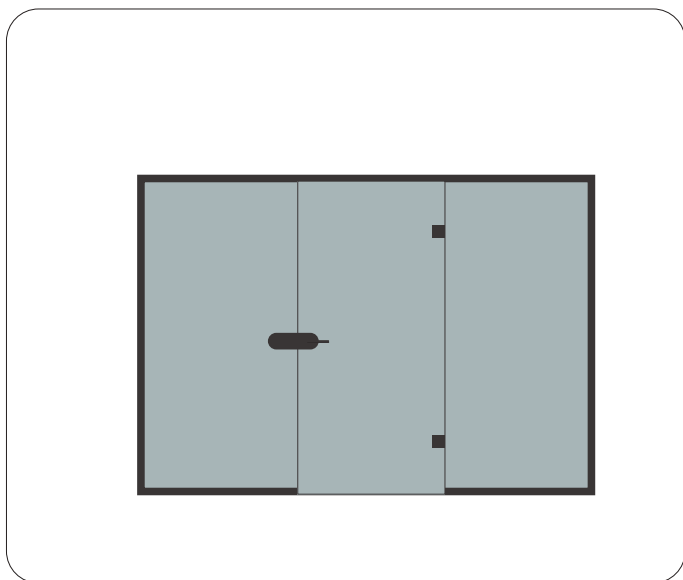
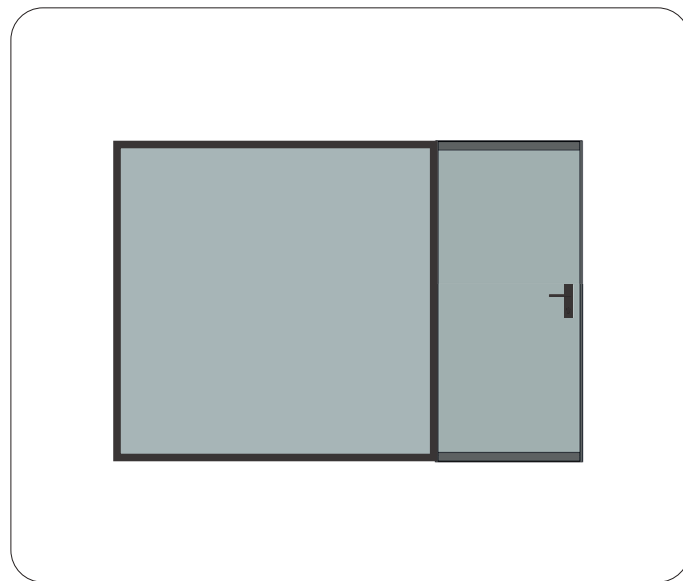
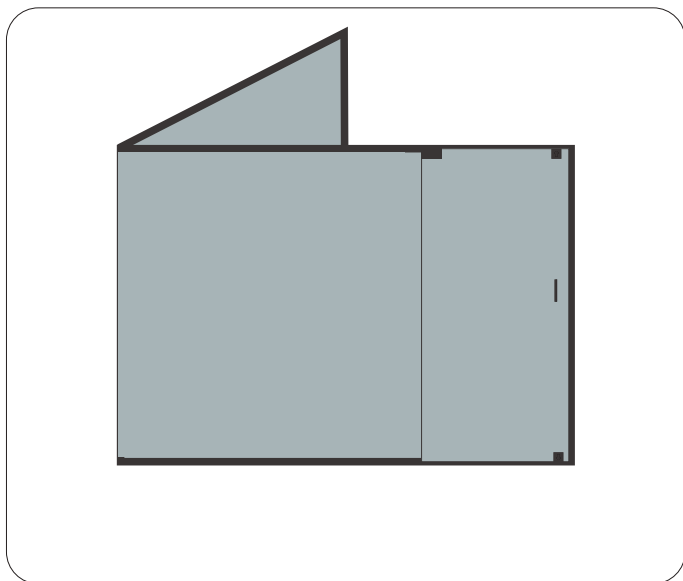
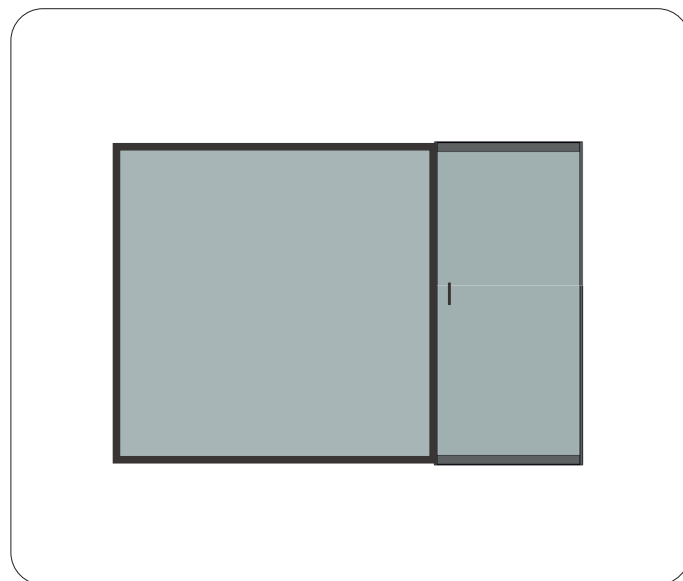
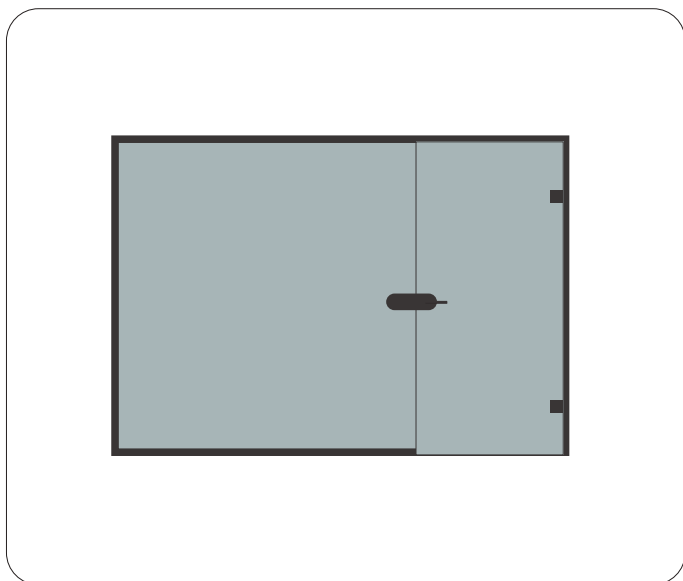

# Profilo 2 Frame 2 | Perfil 2



## Profilo 2 Frame 2 | Perfil 2

1

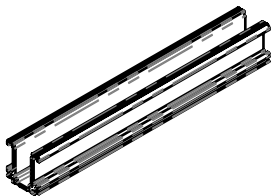

87800  
Profilo WCP7  
WCP7 Profile  
Perfil WCP7

2

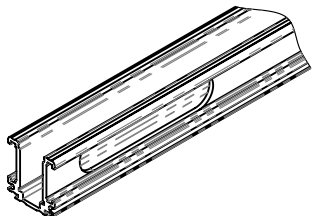

87801  
Profilo WCP7  
WCP7 Profile  
Perfil WCP7

3

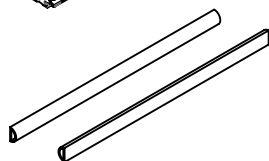

87804  
Guarnizione per profilo  
Profile gasket  
Junta para perfil

4

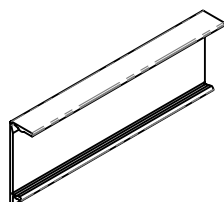

87803  
Copertina in alluminio  
Aluminium cover  
Cubierta en aluminio

7

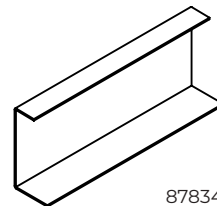

87834  
Copertina montante centrale  
Central jamb cover  
Cubierta para montante central

5

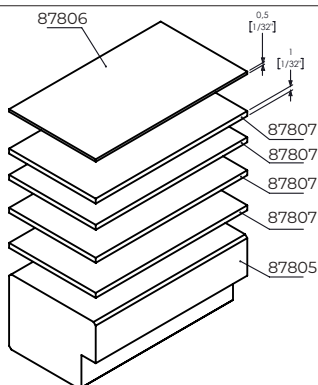

Spessori per vetro  
Glass thickness  
Espesores para vidrio

6

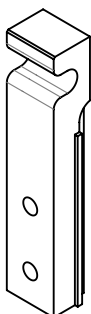

87824  
Attacco montante  
Jamb attack  
Punto de fijación montante

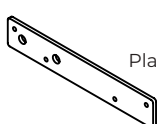

87819  
Dima di foratura  
Drilling template  
Plantilla de perforación

# Profilo 2

## Frame 2 | Perfil 2

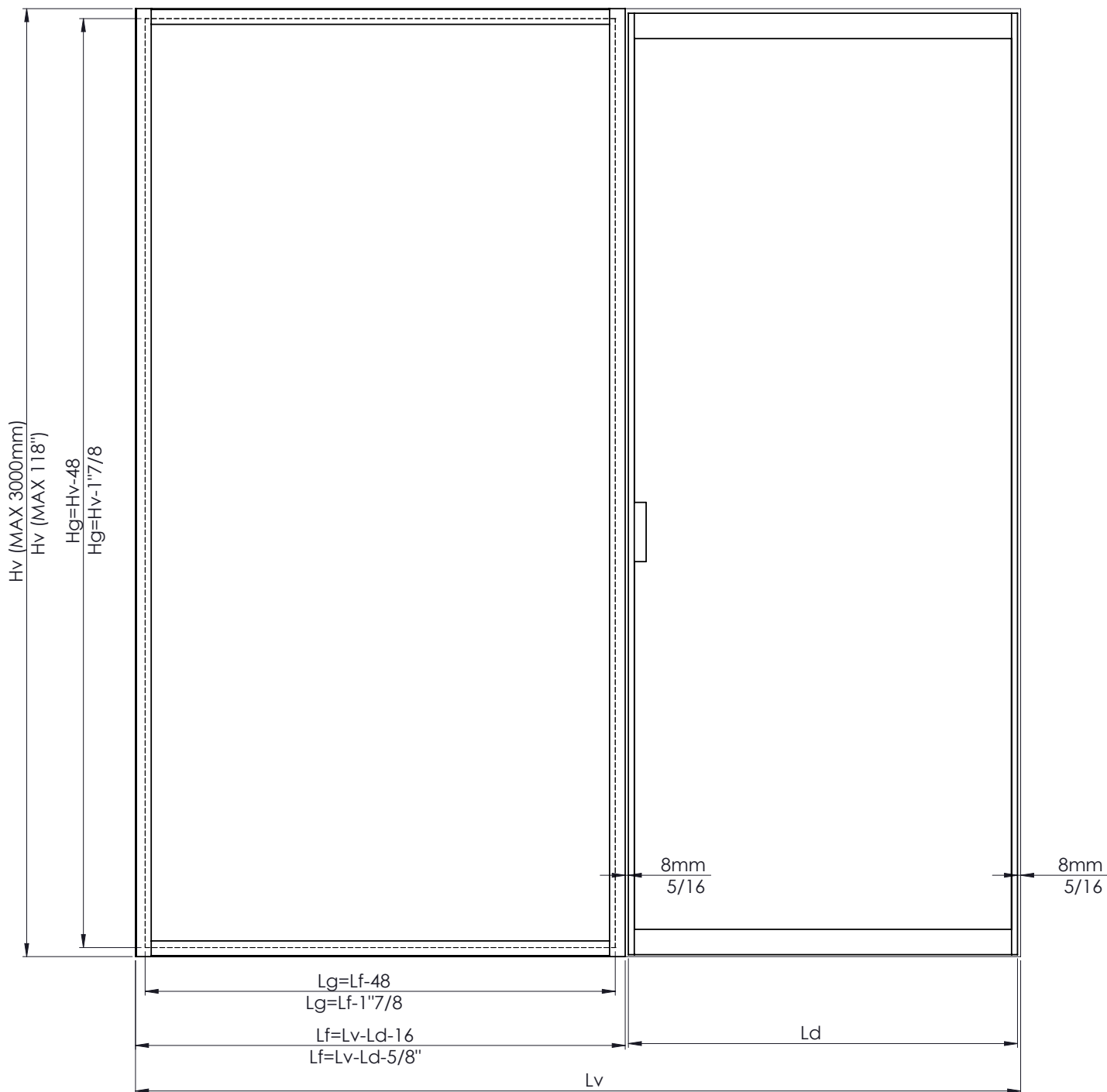

Hv= Altezza vano | Space height | Altura espacio

Hg= Altezza vetro fisso | Fixed glass height | Altura vidrio fijo

Lv= Larghezza vano | Space width | Ancho espacio

Ld= Larghezza porta | Door width | Ancho puerta

Lf= Larghezza frame inferiore | Lower frame width | Ancho marco inferior

Lg= Larghezza vetro fisso | Fixed glass width | Ancho vidrio fijo

# Componenti

Components | Componentes

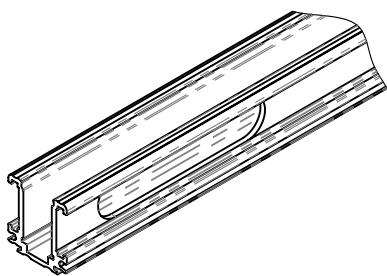

Profilo  
Profile  
Perfil

87801

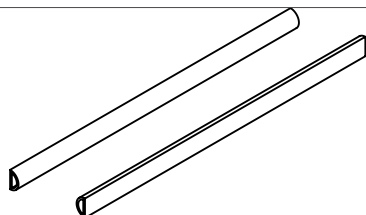

Guarnizione per profilo  
Profile gasket  
Junta para perfil

87804

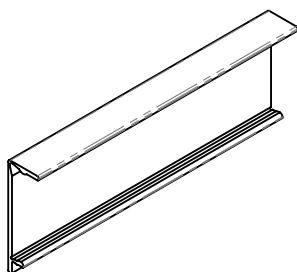

Copertina per profilo  
Profile cover  
Cubierta para perfil

87803

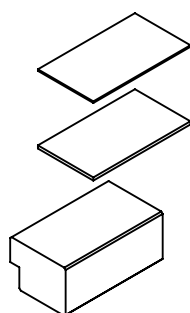

Kit distanziali vetro  
Kit glass spacer  
Kit distanciales para vidrio

Kit Distanziali

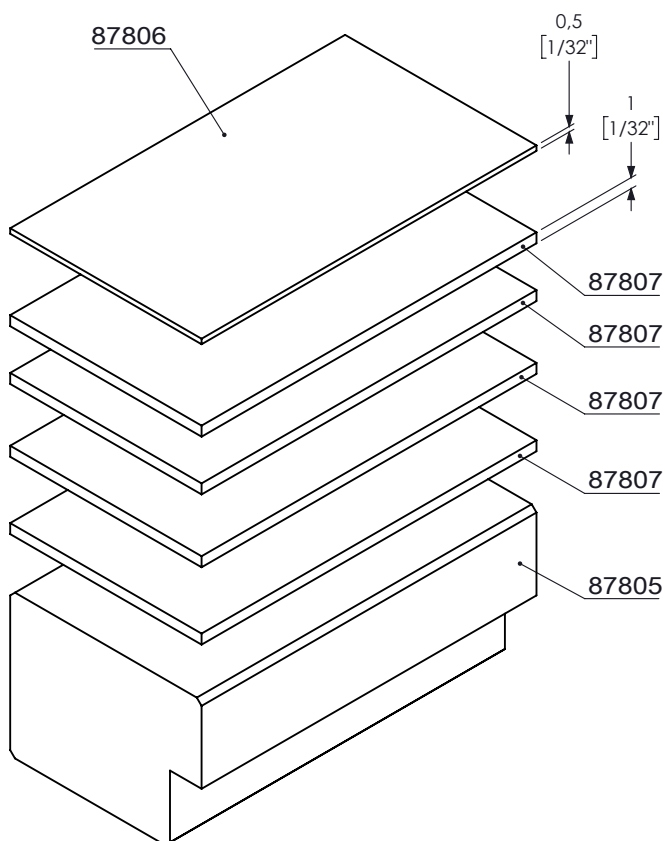
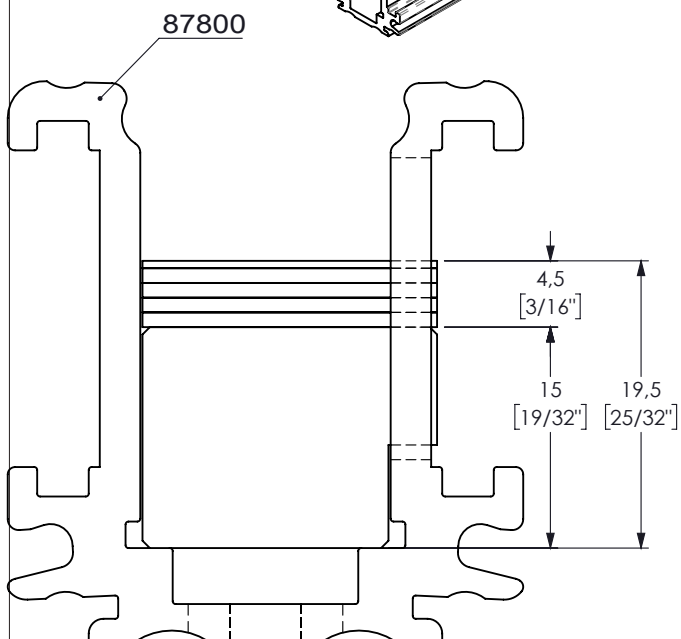
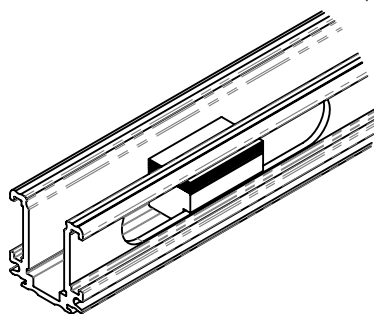

# Componenti

Components | Componentes

## Kit catenaccio

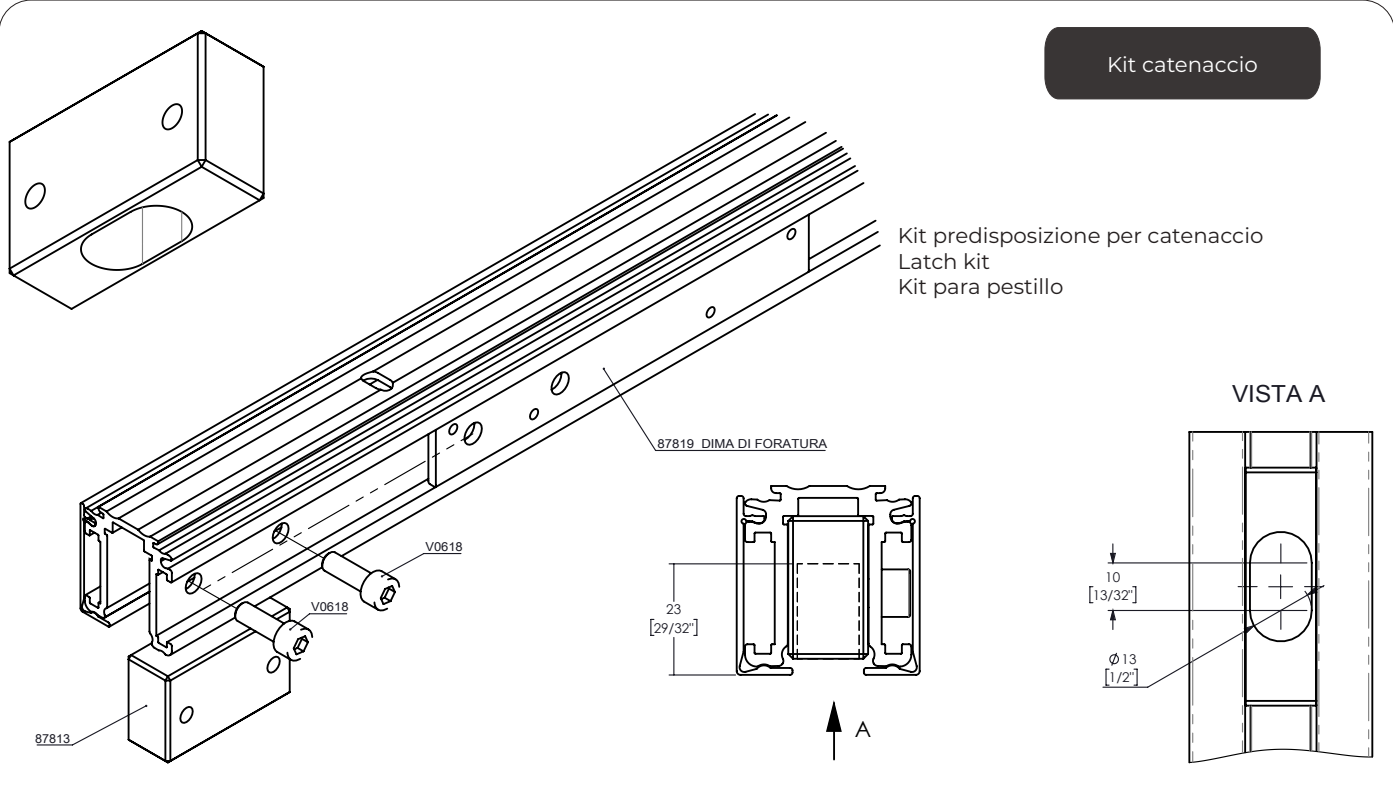

## Kit perno

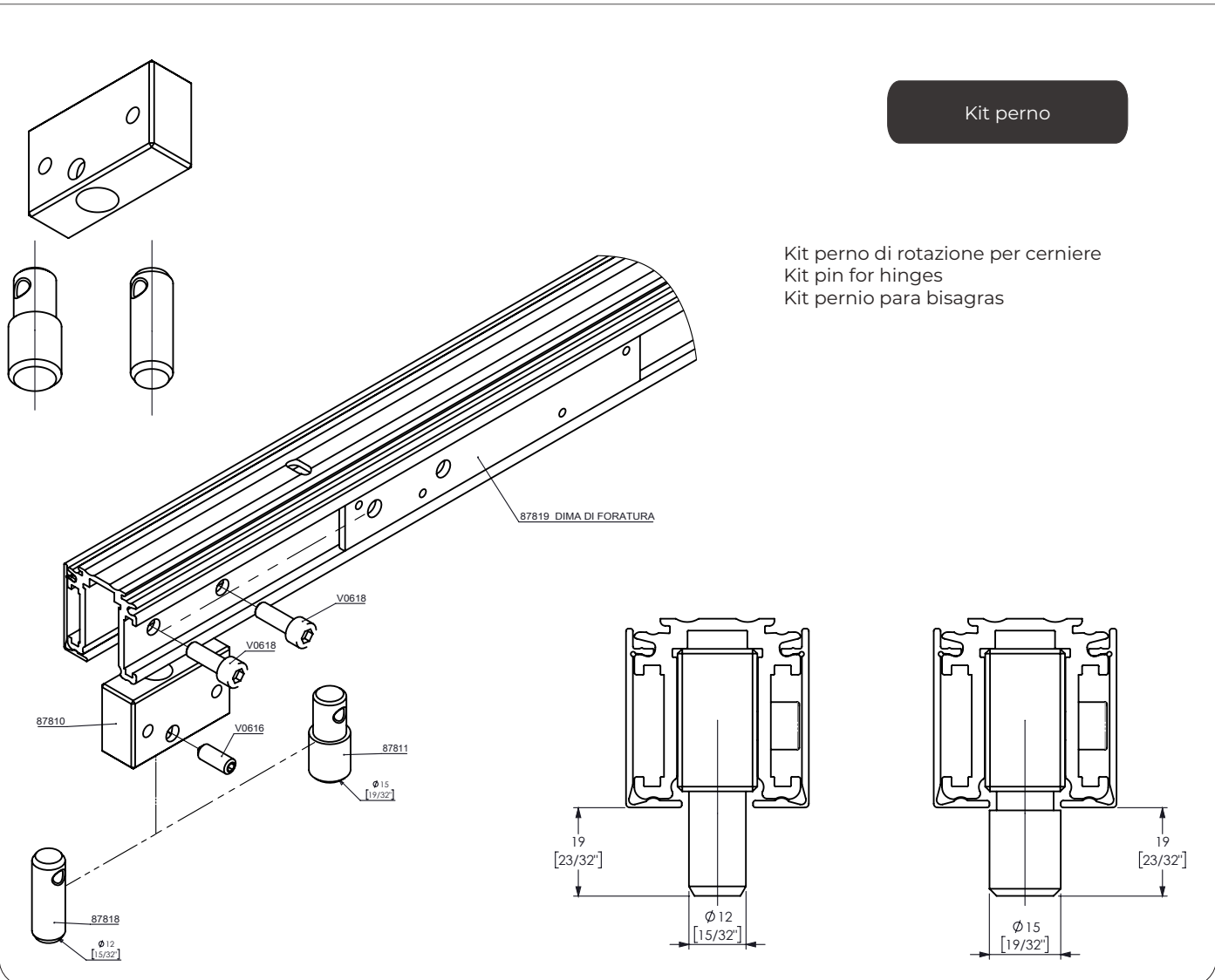

# Componenti

Components | Componentes

**Kit tappi chiusura per profilo**  
 Profile end caps kit  
 Kit tapitas lateral para perfil

**Kit frontalino**

SEZIONE A-A

V0610  
87822  
87823

**Guarnizione copri-cava profilo**  
 Gasket for profile  
 Junta para perfil

87831

**Dima di foratura**  
 Marking template  
 Plantilla de perforación

87819

**Kit battuta porta**

Kit battuta porta  
 Kit rebated door  
 Kit puerta con tope

87814

V0616  
87818  
87815

10  
[13/32"]

V0616  
87817  
87815

12  
[15/32"]

# Componenti

Components | Componentes

Kit porta frame Tabula

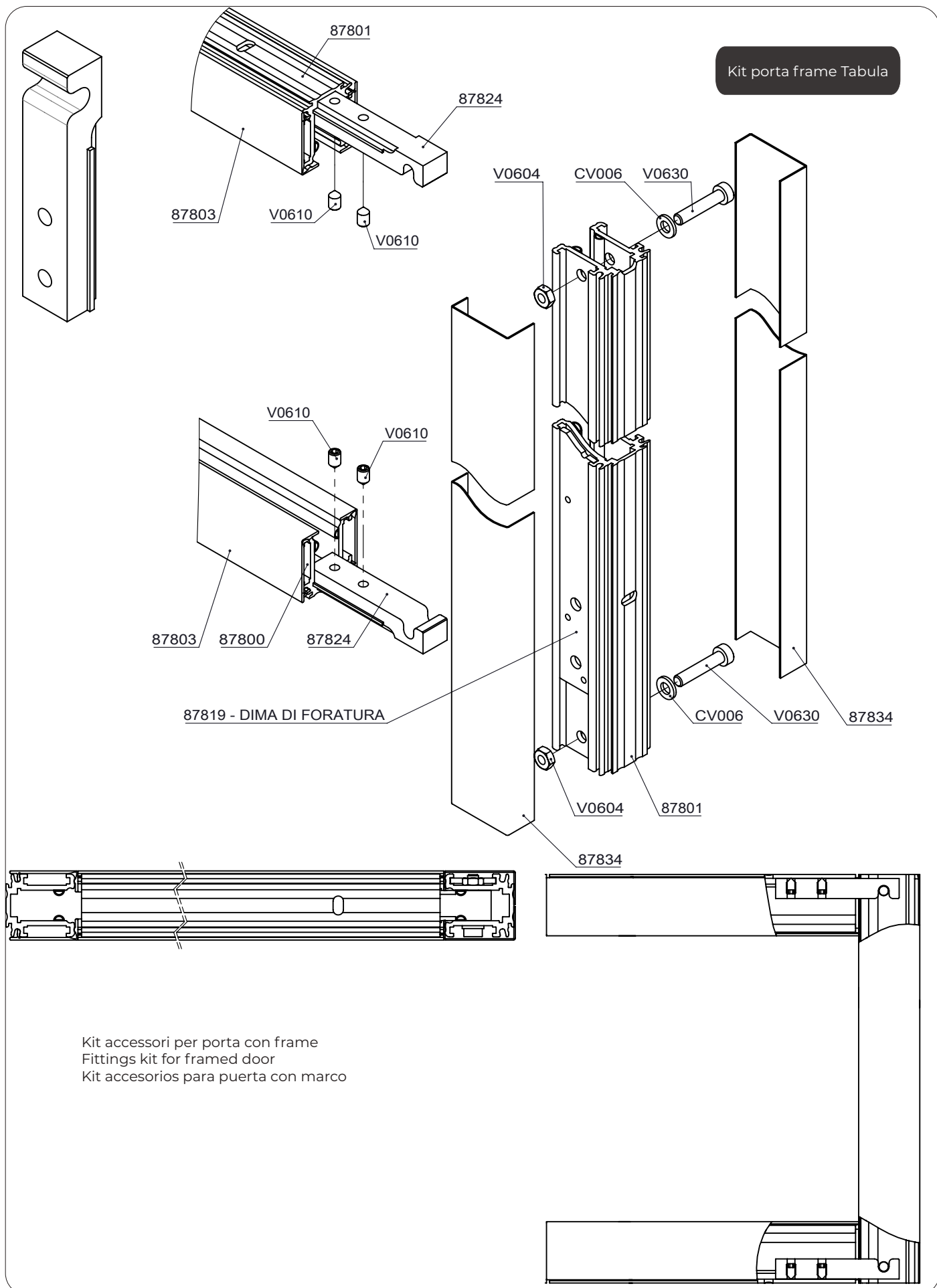

Kit accessori per porta con frame  
Fittings kit for framed door  
Kit accesorios para puerta con marco



41AL



Spessore vetro  
Glass thickness  
Espesor del vidrio

8 ÷ 16 mm\*  
0 5/16" ÷ 0 5/8"

\*Ulteriori spessori su richiesta  
\*More thicknesses upon request  
\*Más espesores bajo pedido



Spessore vetro porta  
Glass door thickness  
Espesor del vidrio de la puerta

8 ÷ 12 mm  
0 5/16" ÷ 0 15/32"



EN ISO 10140

Isolamento acustico 37 dB  
Sound insulation 37 dB  
Aislamiento acústico 37 dB

Isolamento acustico secondo EN ISO 10140  
Sound insulation to EN ISO 10140  
Aislamiento acústico EN ISO 10140



SETUP A: Glass door incl. drop-down seal with glass side panel

Finiture standard  
Standard finishes  
Acabados estándar

611

Alluminio anodizzato naturale  
Silver anodized aluminum  
Aluminio anodizado natural

620

Alluminio anodizzato nero  
Black anodized aluminum  
Aluminio anodizado negro

680

Alluminio anodizzato simil inox  
Similar to stainless steel aluminum  
Aluminio anodizado similar acero inoxidable

41AL | Profile | Basis G

Profilo in alluminio con guarnizione TPE  
Aluminium profile with gasket TPE  
Perfil en aluminio con junta TPE



Componenti  
Components | Componentes

AL-Basis-D  
AL-Clip-D  
AL-EPDM-B  
AL-EPDM-8/10/12\*  
AL-EPDM-F

41AL | Profile | Basis W

Profilo in alluminio con guarnizione TPE  
Aluminium profile with gasket TPE  
Perfil en aluminio con junta TPE



Componenti  
Components | Componentes

AL-Basis-D  
AL-EPDM-B

41AL | Frame profile | Frame

Profilo in alluminio con guarnizione TPE  
Aluminium profile with gasket TPE  
Perfil en aluminio con junta TPE



Componenti  
Components | Componentes

AL-Frame-D  
AL-Clip-D  
AL-EPDM-8/10/12\*  
AL-EPDM-F

41AL | Parete vetrata | Configurazioni possibili

41AL | Glass wall | Possible configurations  
 41AL | Pared de vidrio | Configuraciones posibles

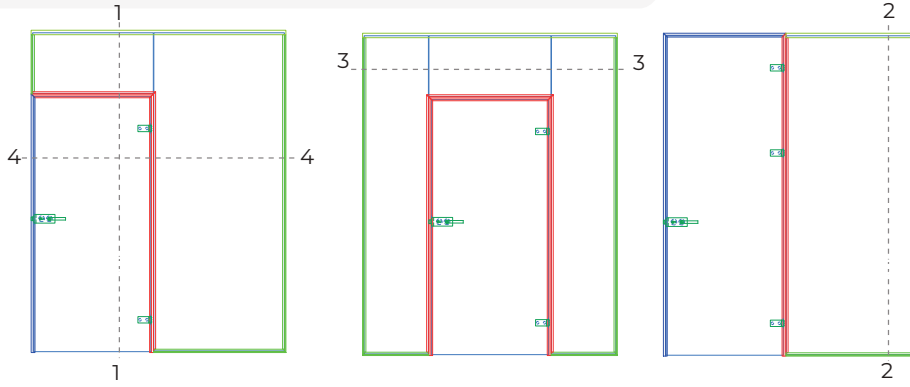

AL-Basis-W

AL-Basis-G

AL-Frame

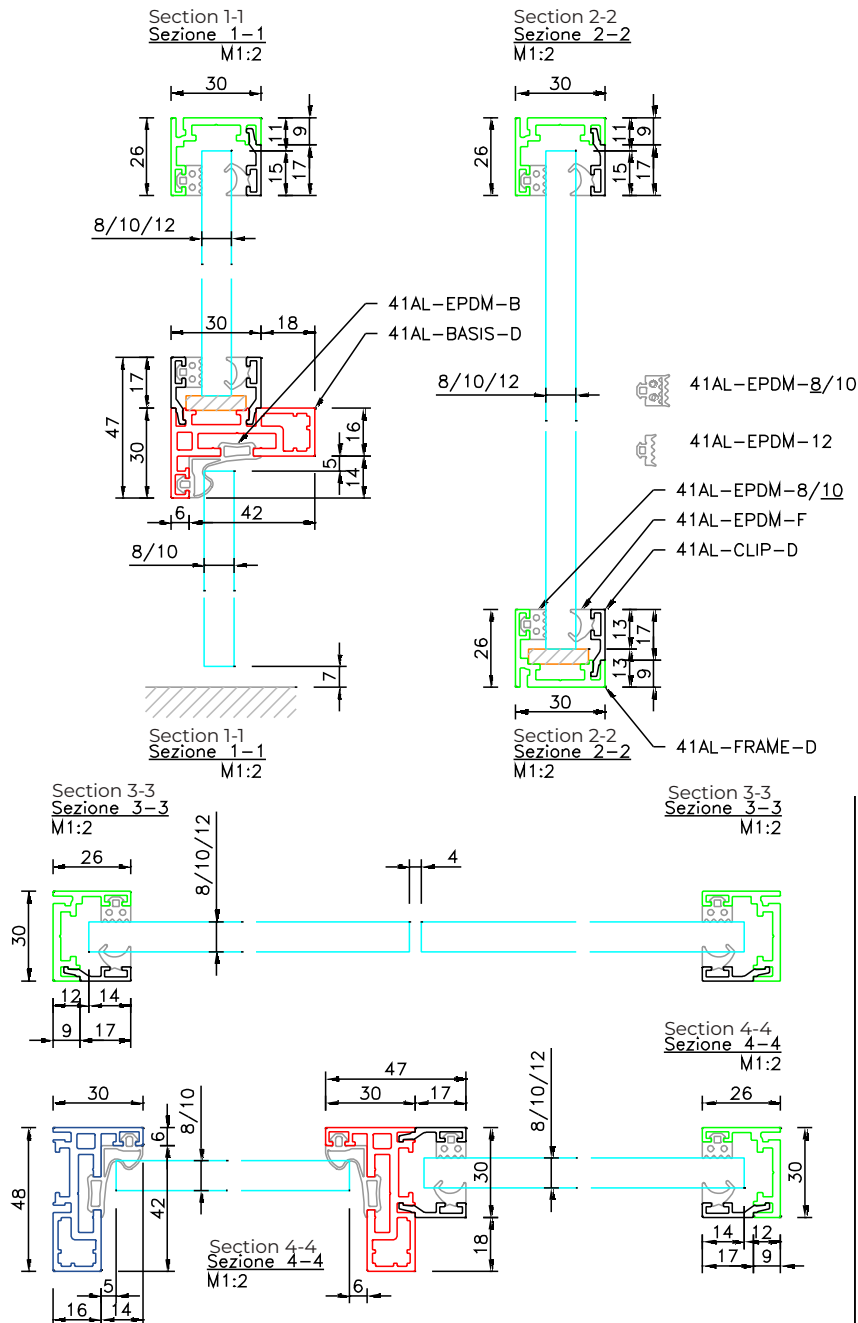

# Componenti

## Components | Componentes

**AL-BASIS-D**

Profilo  
Frame  
Perfil

**AL-FRAME-D**

Profilo  
Frame  
Perfil

**AL-CLIP-D**

Copertina profilo  
Frame cover  
Cubierta para perfil

**AL-OFFICE-C**

Connettore pavimento e angolo  
Floor and corner connector  
Conector suelo y ángulo

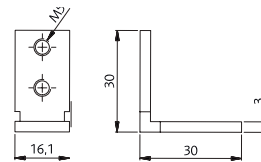
**AL-OFFICE-CT**

Connettore a T per profili  
Basis and top frame connector  
Conector para perfiles

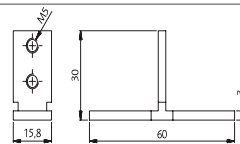
**AL-OFFICE-CH**

Connettore orizzontale a 90° per profili a soffitto e a pavimento  
90° corner horizontal for ceiling and floor profiles connector  
Conector horizontal a 90° para perfiles a techo o a suelo

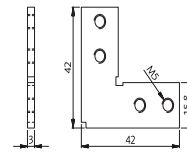
**AL-OFFICE-H**

Dado a testa di martello 10 mm  
Hammerhead nut 10 mm  
Dado hammerhead 10 mm

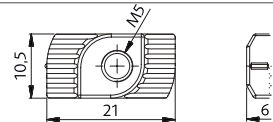
**AL-OFFICE-H12**

Dado a testa di martello 12 mm  
Hammerhead nut 12 mm  
Dado hammerhead 12 mm

**AL-OFFICE-CP**

Bocchetta 10-12 mm  
Striking plate XL 10-12 mm  
Cerradero 10-12 mm

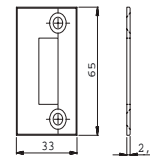
**Guarnizioni | Gaskets | Chapas**

**AL-EPDM-8/10/12**  
Guarnizione ferma vetro 8/10/12 mm  
Glass gasket 8/10/12 mm  
Junta para vidrio 8/10/12 mm



**AL-EPDM-16**  
Guarnizione ferma vetro 16 mm  
Glass gasket 16 mm  
Junta para vidrio 16 mm



**AL-EPDM-F**  
Guarnizione per il fissaggio  
Gasket Fixed rubber  
Junta para fijación



**AL-EPDM-B**  
Guarnizione per profili  
Frame gasket  
Junta para perfiles

# Componenti

## Components | Componentes

**Latus80 | 4L8XS**  
Cerniera idraulica  
Hydraulic hinge  
Bisagra hidraulica

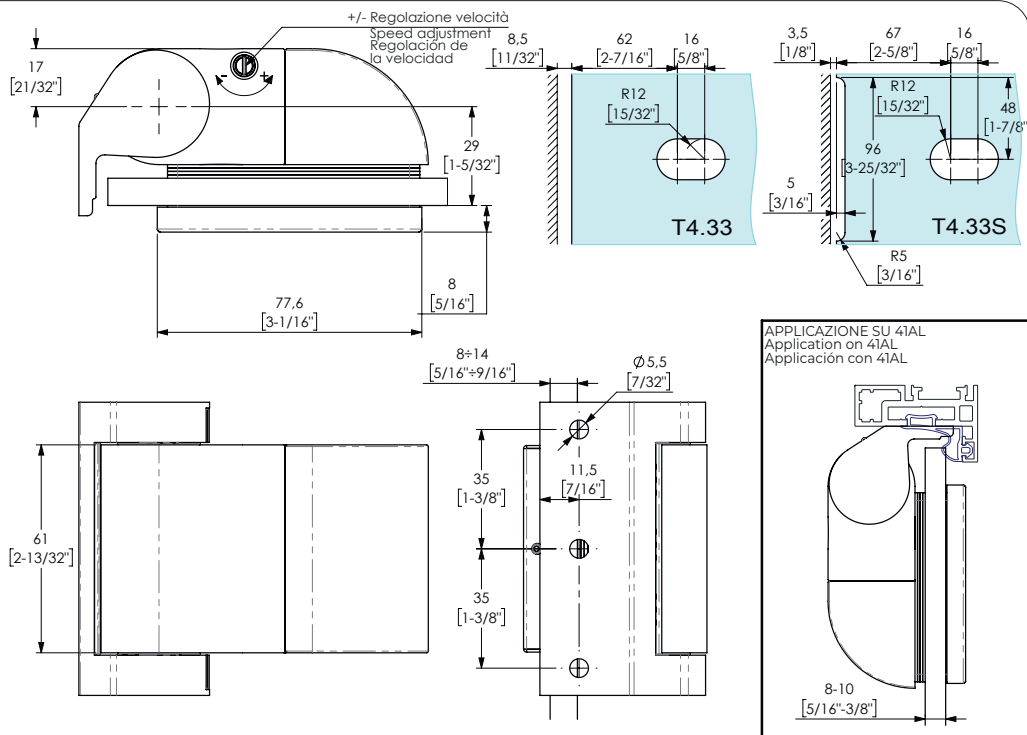

**Claustra | 13200**  
Cerniera  
Hinge  
Bisagra

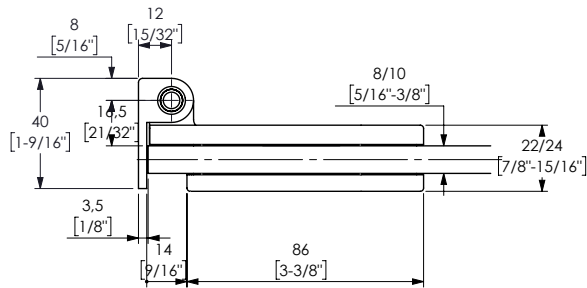
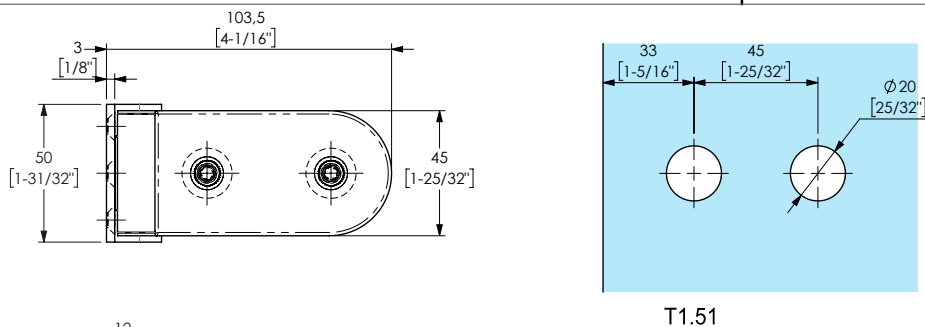

**i** Compatibile con sistema 41AL XL  
Compatible with 41AL XL  
Compatible con sistema 41AL XL



**Quadra | 13100**  
Cerniera  
Hinge  
Bisagra

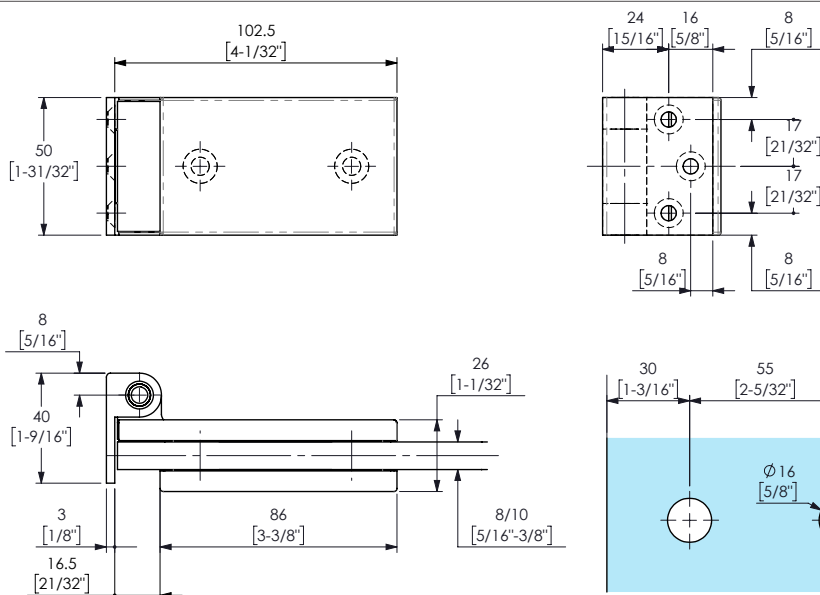

**i** Compatibile con sistema 41AL XL  
Compatible with 41AL XL  
Compatible con sistema 41AL XL

**T1.03**

# Componenti

## Components | Componentes



**Derecta | 13137**  
Cerniera verticale  
Vertical lock  
Bisagra vertical

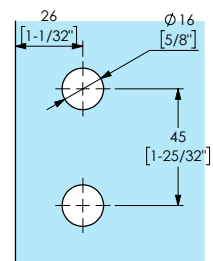
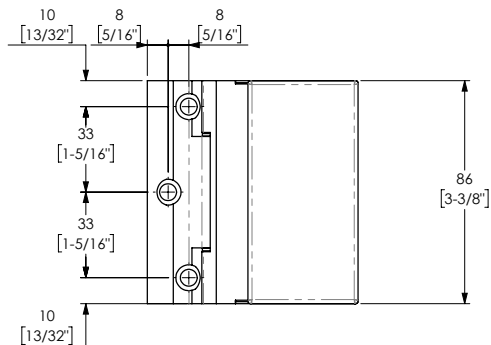

T1.62

**i** Compatibile con sistema 4IAL XL  
Compatible with 4IAL XL  
Compatible con sistema 4IAL XL

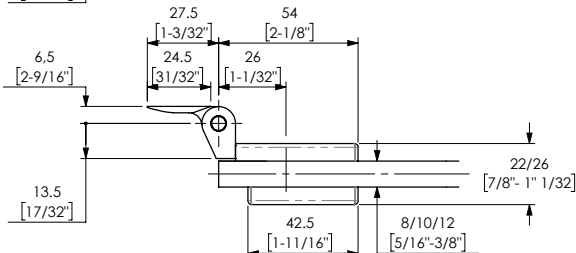

**Derecta | 13138**  
Cerniera verticale  
Vertical lock  
Bisagra vertical

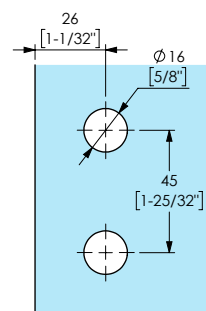
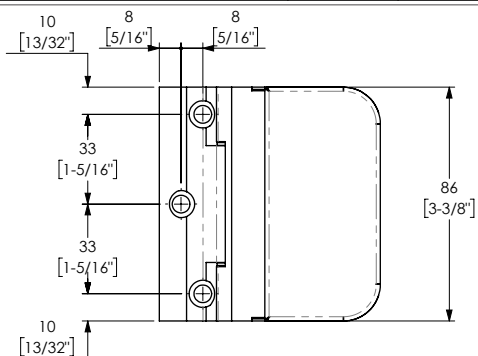

T1.62

**i** Compatibile con sistema 4IAL XL  
Compatible with 4IAL XL  
Compatible con sistema 4IAL XL

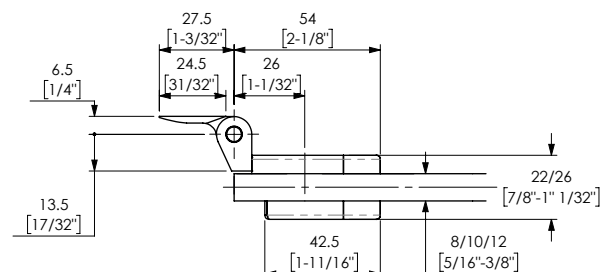

**Derecta | 13139**  
Cerniera verticale  
Vertical hinge  
Bisagra vertical

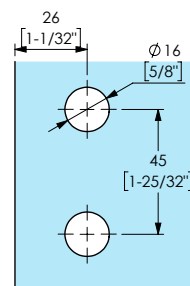
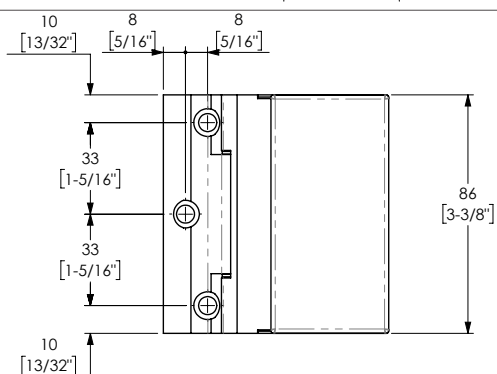

T1.62

**i** Compatibile con sistema 4IAL XL  
Compatible with 4IAL XL  
Compatible con sistema 4IAL XL

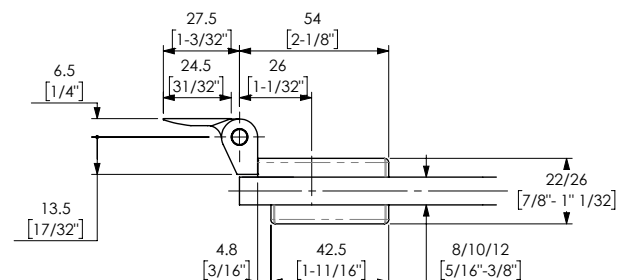

# Componenti

Components | Componentes



**Quadra | 15100**

Serratura  
Lock  
Cerradura

**!** Cilindro suggerito 19143 (non incluso)  
Suggested cylinder 19143 (not included)  
Cilindro aconsejado 19143 (no incluye)

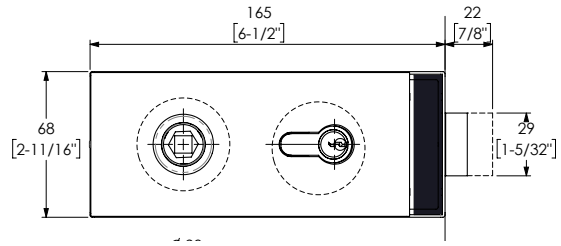
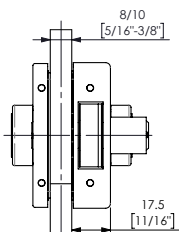

**i** Compatibile con sistema 41AL XL  
Compatible with 41AL XL  
Compatible con sistema 41AL XL



**Clastra | 15200**

Serratura  
Lock  
Cerradura

**!** Cilindro suggerito 19143 (non incluso)  
Suggested cylinder 19143 (not included)  
Cilindro aconsejado 19143 (no incluye)

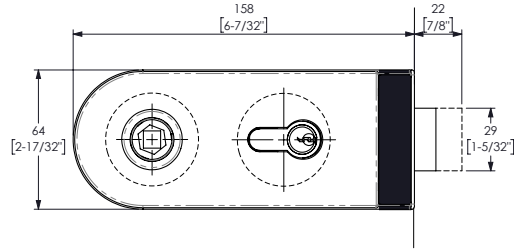
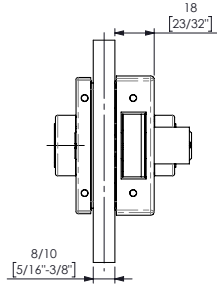

**i** Compatibile con sistema 41AL XL  
Compatible with 41AL XL  
Compatible con sistema 41AL XL



**Clastra | 15910**

Serratura magnetica  
Magnetic lock  
Cerradura magnetica

**!** Cilindro suggerito 19143 (non incluso)  
Suggested cylinder 19143 (not included)  
Cilindro aconsejado 19143 (no incluye)

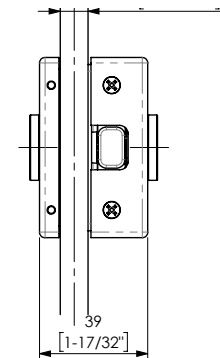
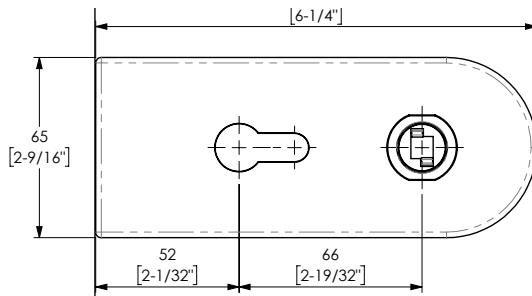

**i** Compatibile con sistema 41AL XL  
Compatible with 41AL XL  
Compatible con sistema 41AL XL



**Quadra | 15912**

Serratura magnetica  
Magnetic lock  
Cerradura magnetica

**!** Cilindro suggerito 19143 (non incluso)  
Suggested cylinder 19143 (not included)  
Cilindro aconsejado 19143 (no incluye)

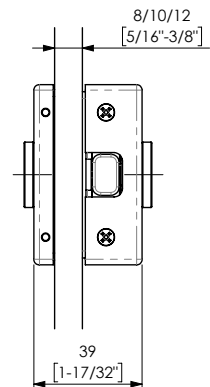
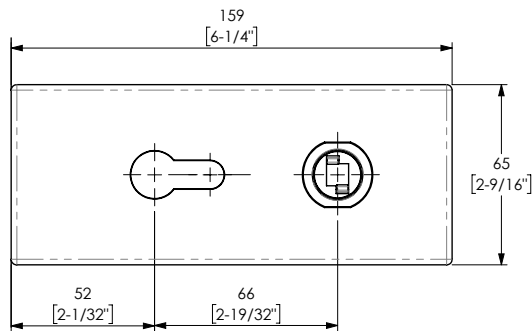

**i** Compatibile con sistema 41AL XL  
Compatible with 41AL XL  
Compatible con sistema 41AL XL

**Quadra-Clastra | 15915**

Piastrina per serratura magnetica  
Strike plate for magnetic lock  
Chapa para cerradura magnetica

**!** Richiede lavorazione del montante  
Frame working requested  
Requiere elaboración de extrusión

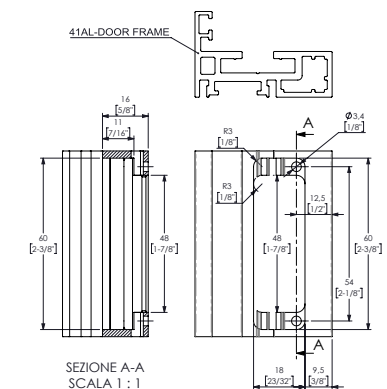
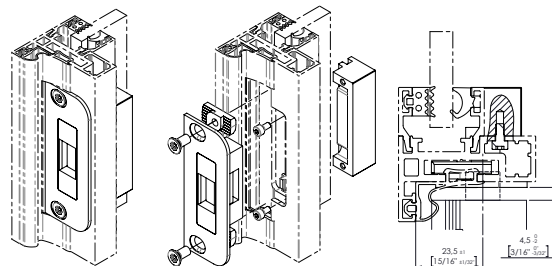

# Componenti Components | Componentes

Piastrina per serratura magnetica  
Strike plate for magnetic lock  
Chapa para cerradura magnetica

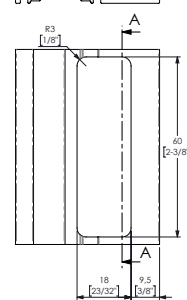
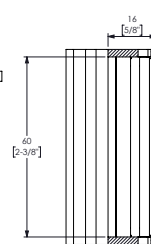
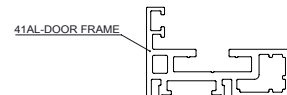
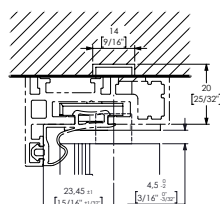
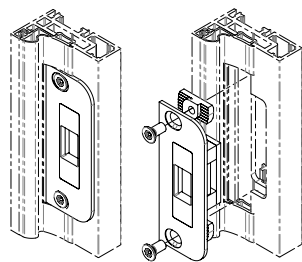

SEZIONE A-A  
SCALA 1 : 1



Richiede lavorazione del montante  
Frame working requested  
Requiere elaboración de extrusión



Directa| 15901-2  
Serratura verticale  
Vertical lock  
Cerradura vertical

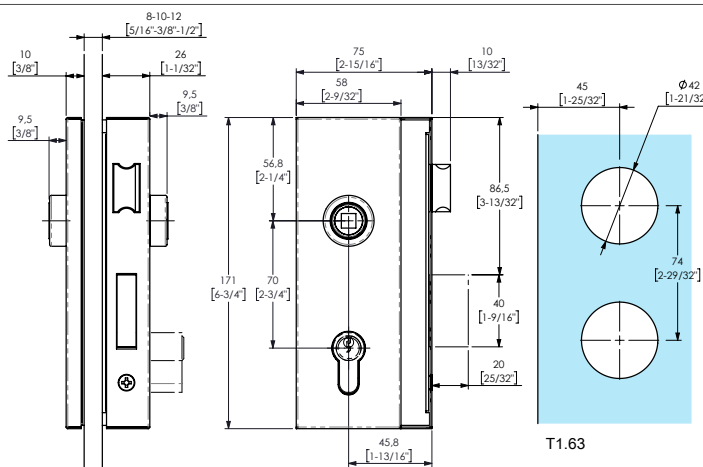

T1.63



Cilindro suggerito 19143 (non incluso)  
Suggested cylinder 19143 (not included)  
Cilindro aconsejado 19143 (no incluye)

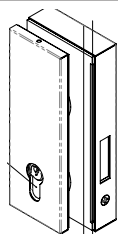

Directa| 15922  
Serratura verticale  
Vertical lock  
Cerradura vertical

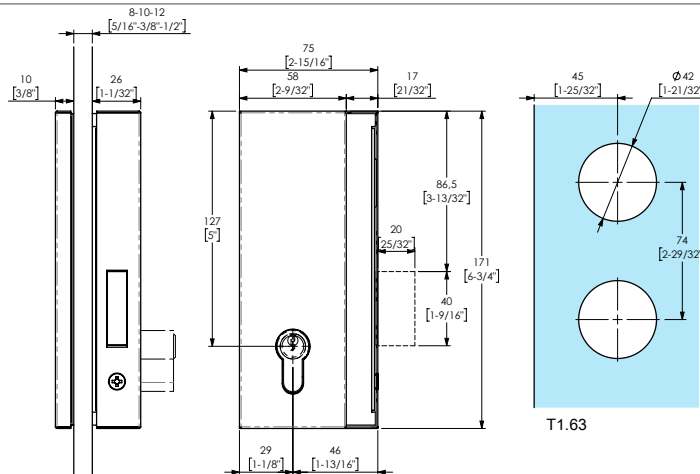

T1.63



Cilindro suggerito 19143 (non incluso)  
Suggested cylinder 19143 (not included)  
Cilindro aconsejado 19143 (no incluye)

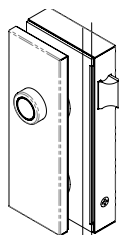

Directa| 15931-2  
Serratura verticale  
Vertical lock  
Cerradura vertical

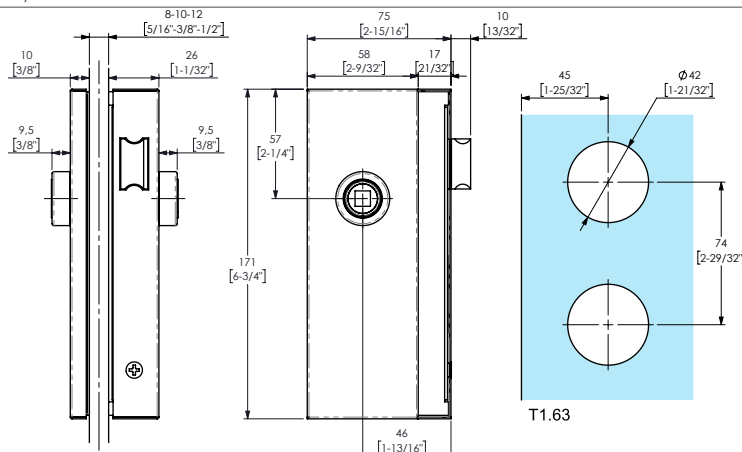

T1.63



Cilindro suggerito 19143 (non incluso)  
Suggested cylinder 19143 (not included)  
Cilindro aconsejado 19143 (no incluye)

# Componenti

Components | Componentes

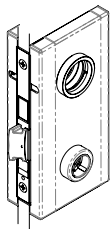

**Derecta| 16352 | DIN L**

Serratura verticale  
cilindro US  
Vertical lock  
Cerradura vertical

**Derecta| 16353 | DIN R**

Serratura verticale  
cilindro US  
Vertical lock  
Cerradura vertical

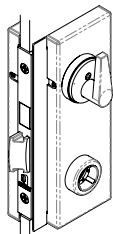
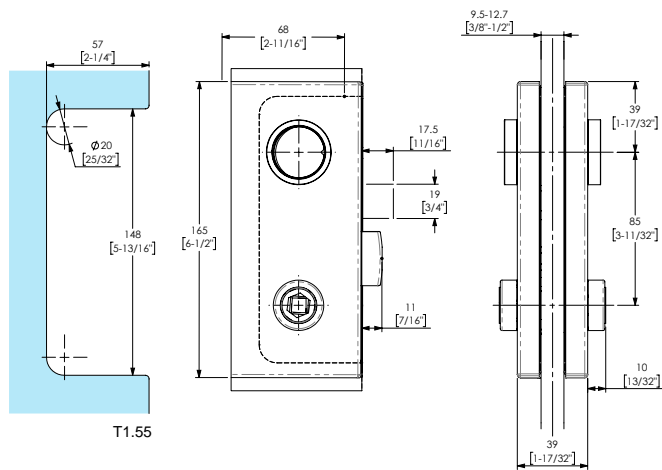

**Derecta| 16361 | DIN L**

Serratura verticale  
cilindro US  
Vertical lock  
Cerradura vertical

**Derecta| 16362 | DIN R**

Serratura verticale  
cilindro US  
Vertical lock  
Cerradura vertical

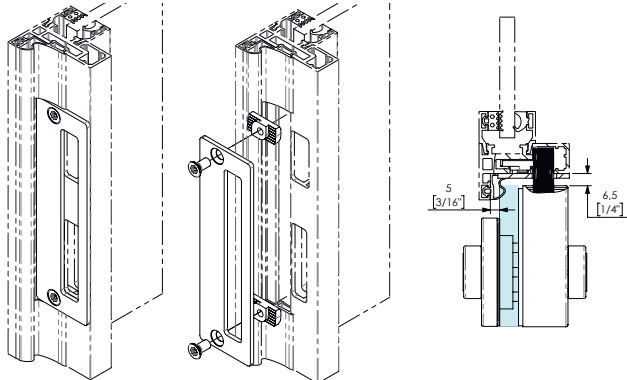
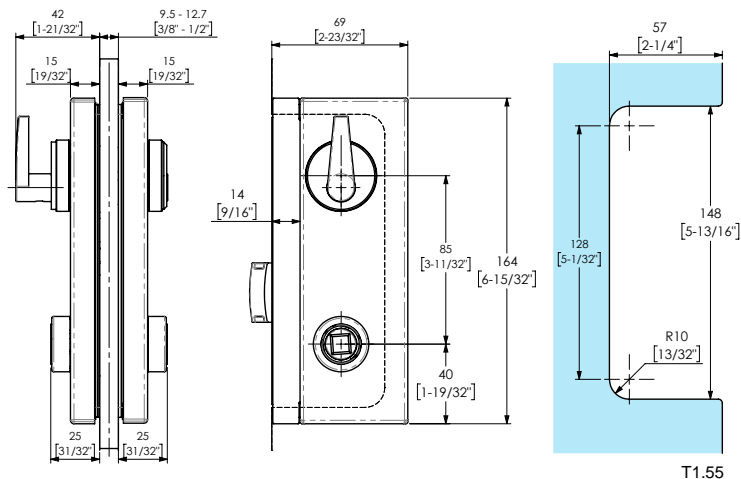

**Derecta| 15482**

Piastrina per serratura  
verticale  
Strike plate for vertical  
lock  
Chapa para cerradura  
vertical



Richiede lavorazione del montante  
Frame working requested  
Requiere elaboración de extrusión



41ALXL



**Finiture standard  
Standard finishes  
Acabados estándar**

611

Alluminio anodizzato naturale  
Silver anodized aluminum  
Aluminio anodizado natural

620

Alluminio anodizzato nero  
Black anodized aluminum  
Aluminio anodizado negro

680

Alluminio anodizzato simil inox  
Similar to stainless steel aluminum  
Aluminio anodizado similar acero inoxidable



Spessore vetro  
Glass thickness  
Espesor del vidrio

20 ÷ 28 mm\*

0 25/32" ÷ 1 7/64"

\*Ulteriori spessori su richiesta

\*More thicknesses upon request

\*Más espesores bajo pedido



Spessore vetro porta

Glass door thickness  
Espesor del vidrio de la puerta

10 ÷ 12 mm

0 25/64" ÷ 0 3/64"



EN ISO 10140

Isolamento acustico 42dB  
Sound insulation 42 dB  
Aislamiento acústico 42 dB

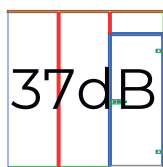

SETUP A: Glass door incl. drop-down seal with glass side panels and fanlight

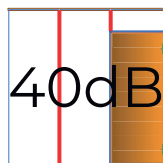

SETUP B: Wooden sound-proof door incl. drop-down seal with glass side panels and fanlight

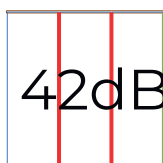

SETUP C: Fixed glazing

Isolamento acustico secondo EN ISO 10140  
Sound insulation to EN ISO 10140  
Aislamiento acústico EN ISO 10140

#### 41AL XL | Basis G XL | Profile

Profilo in alluminio con guarnizione TPE  
Aluminium profile with gasket TPE  
Perfil en aluminio con junta TPE



Componenti | Components | Componentes

AL-Basis-D-XL  
AL-Clip-Basis-D-XL  
AL-EPDM-B-XL  
AL-EPDM-8/10/12\*

#### 41AL XL | Basis W XL | Profile

Profilo in alluminio con guarnizione TPE  
Aluminium profile with gasket TPE  
Perfil en aluminio con junta TPE



Componenti | Components | Componentes

AL-EPDM-F  
AL-Basis-D-XL  
AL-Clip-Basis-D-XL  
AL-EPDM-B

#### 41AL XL | Frame XL | Frame profile

Profilo in alluminio con guarnizione TPE  
Aluminium profile with gasket TPE  
Perfil en aluminio con junta TPE



Componenti | Components | Componentes

AL-Frame-D-XL  
AL-Clip-D  
AL-EPDM-8/10/12\*  
AL-EPDM-F

#### 41AL XL | Frame T XL | Frame profile

Profilo in alluminio con guarnizione TPE  
Aluminium profile with gasket TPE  
Perfil en aluminio con junta TPE



Componenti | Components | Componentes

AL-Frame T-D-XL  
AL-Clip-D (x2)  
AL-EPDM-8/10/12\*  
AL-EPDM-F

41AL XL | Parete vetrata | Configurazioni possibili

41ALXL | Glass wall | Possible configurations  
 41ALXL | Pared de vidrio | Configuraciones posibles

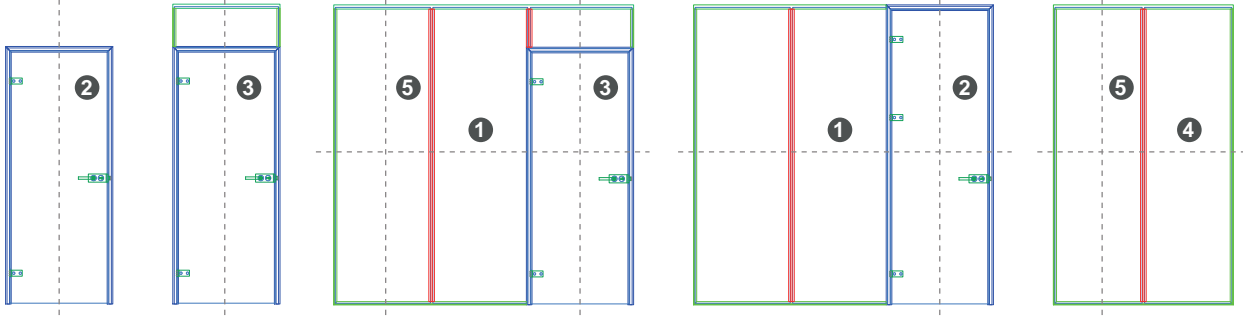

AL-Basis-XL

AL-Frame-XL

AL-Frame-T-XL

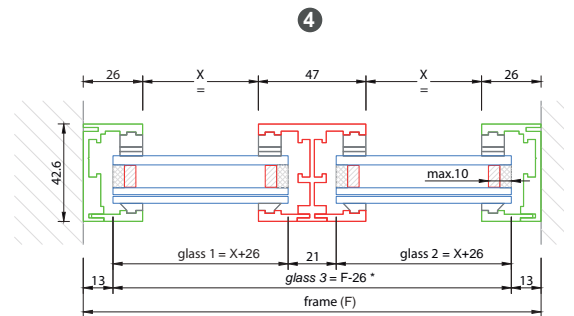
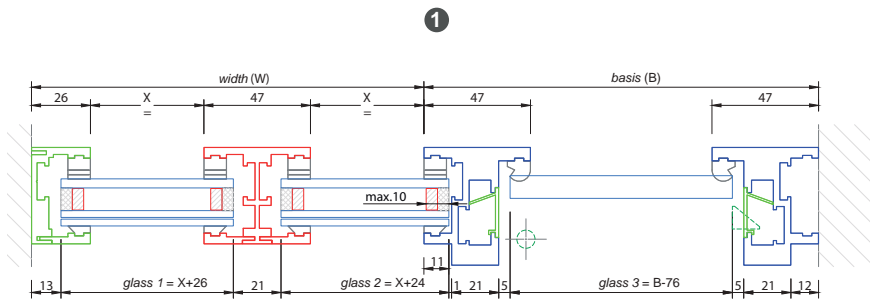

\* without FRAME T XL

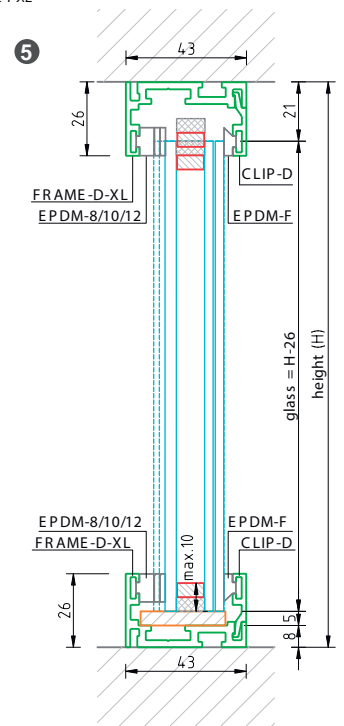
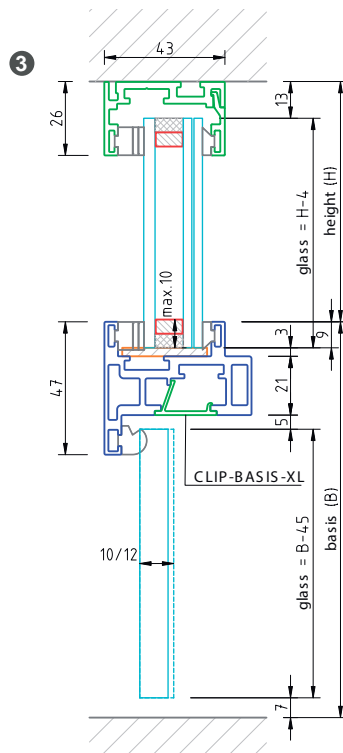
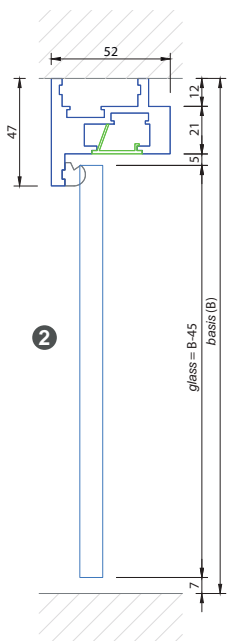

# Componenti

Components | Componentes



**AL-BASIS-D XL**

Profilo  
Frame  
Perfil



**AL-FRAME-D XL**

Profilo  
Frame  
Perfil



**AL-CLIP Basis-D XL**

Copertina profilo  
Frame cover  
Cubierta para perfil



**AL-CLIP-D**

Copertina profilo  
Frame cover  
Cubierta para perfil



**AL-OFFICE-C**

Connettore pavimento e angolo  
Floor and corner connector  
Conector suelo y ángulo

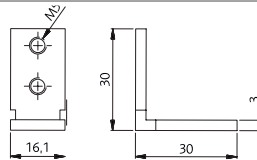

**AL-OFFICE-CT**

Connettore a T per profili  
Basis and top frame connector  
Conector para perfiles

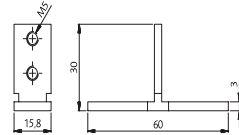

**AL-OFFICE-CH**

Connettore orizzontale a 90° per profili a soffitto e a pavimento  
90° corner horizontal for ceiling and floor profiles connector  
Conector horizontal a 90° para perfiles a techo o a suelo

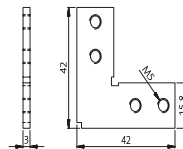

**AL-OFFICE-CZ XL**

Connettore orizzontale per frame  
Frame connector  
Conector para perfiles

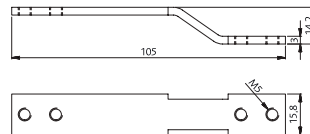

**AL-OFFICE-H XL**

Dado a testa di martello 10/12 mm  
Hammerhead nut 10/12 mm  
Dado hammerhead 10/12 mm

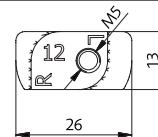

**AL-OFFICE-CP**

Bocchetta 10-12 mm  
Striking plate XL 10-12 mm  
Cerradero 10-12 mm

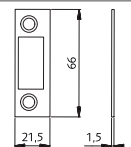

**Guarnizioni | Gaskets | Chapas**



**AL-EPDM-8/10/12**  
Guarnizione ferma vetro 8/10/12 mm  
Glass gasket 8/10/12 mm  
Junta para vidrio 8/10/12 mm



**AL-EPDM-16**  
Guarnizione ferma vetro 16 mm  
Glass gasket 16 mm  
Junta para vidrio 16 mm



**AL-EPDM-F**  
Guarnizione per il fissaggio  
Gasket Fixed rubber  
Junta para fijación



**AL-EPDM-B**  
Guarnizione per profili  
Frame gasket  
Junta para perfiles



**AL-EPDM-B XL**  
Guarnizione fissaggio  
Frame gasket  
Junta para perfiles

# Componenti

Components | Componentes

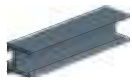

**AL-BASIS-P-D XL**

Profilo  
Frame  
Perfil

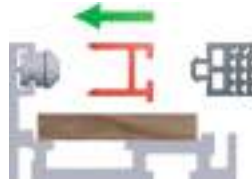

**AL-FRAME-KK XL**

Profilo  
Frame  
Perfil



**AL-CLIP Basis-BL XL**

Copertina profilo  
Frame cover  
Cubierta para perfil

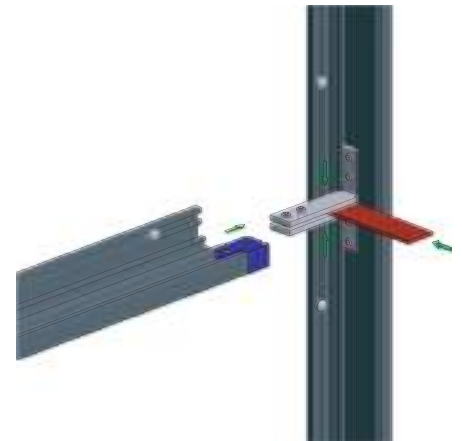

# Componenti

Components | Componentes



**Clastra | 13200**  
Cerniera  
Hinge  
Bisagra

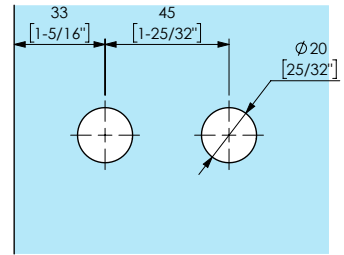
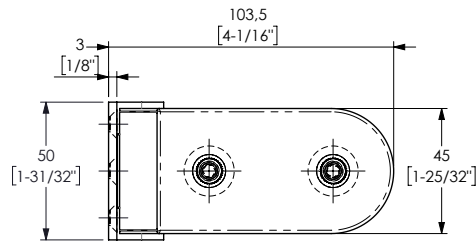

T1.51

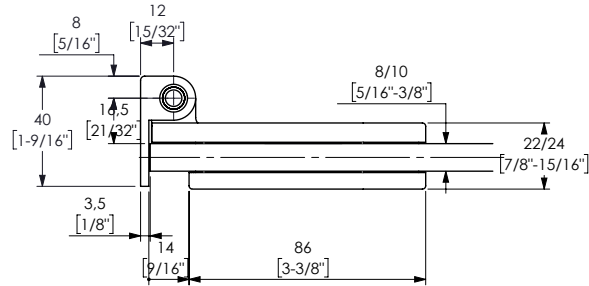

**Quadra | 13100**  
Cerniera  
Hinge  
Bisagra

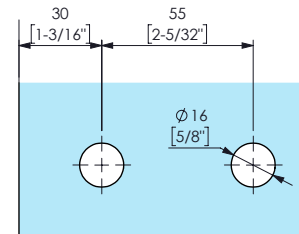
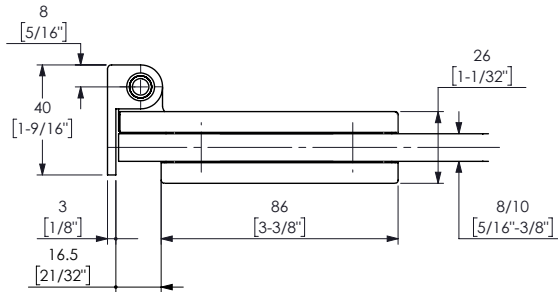
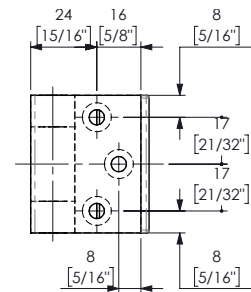
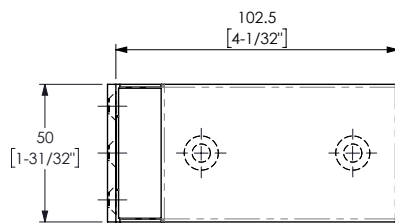

T1.03



**Directa | 13137**  
Cerniera verticale  
Vertical lock  
Bisagra vertical

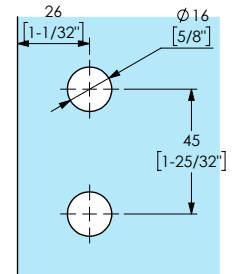
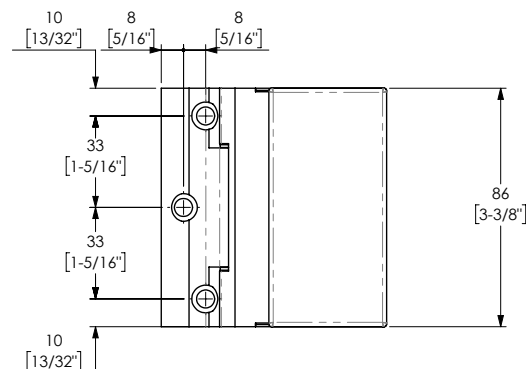

T1.62

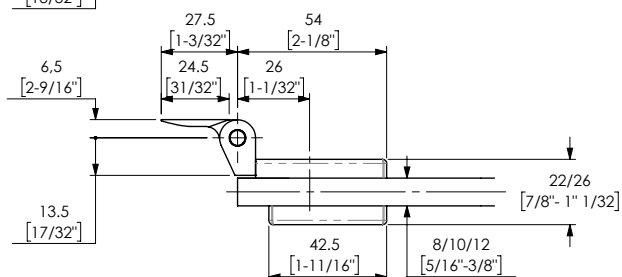

# Componenti

Components | Componentes



**Derecta | 13138**  
Cerniera verticale  
Vertical lock  
Bisagra vertical

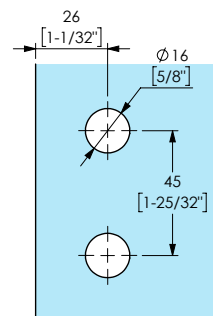
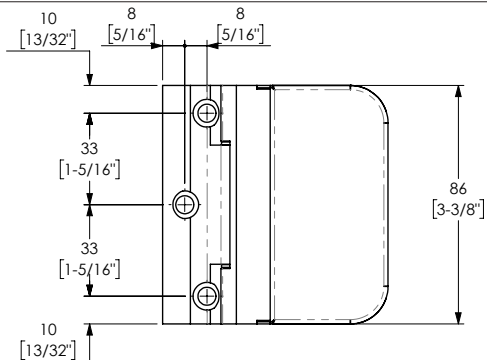

T1.62

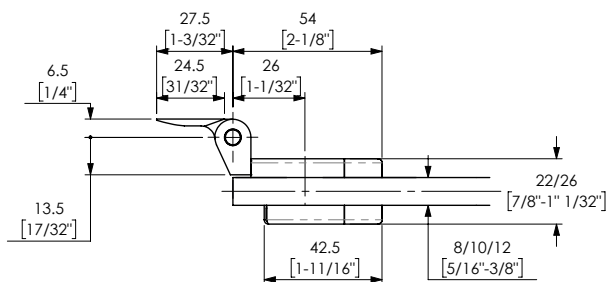

**Derecta | 13139**  
Cerniera verticale  
Vertical hinge  
Bisagra vertical

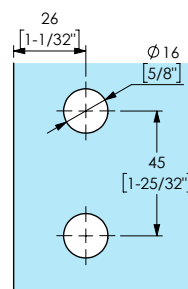
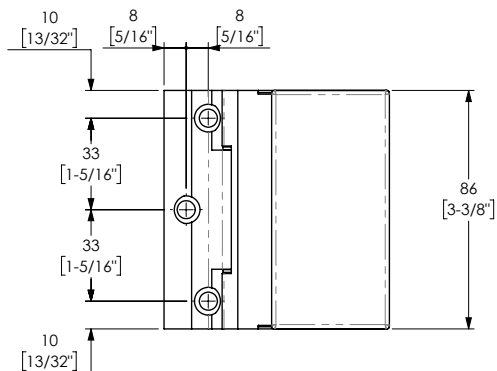

T1.62

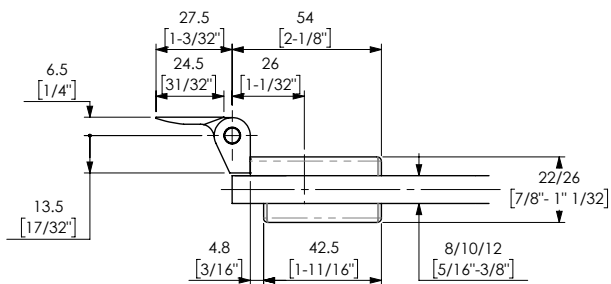

**Quadra | 15100**  
Serratura  
Lock  
Cerradura

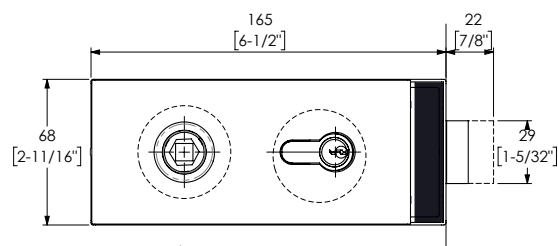
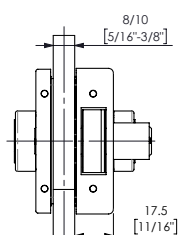

 Cilindro suggerito 19143 (non incluso)  
Suggested cylinder 19143 (not included)  
Cilindro aconsejado 19143 (no incluye)

# Componenti

Components | Componentes



**Claustra | 15200**  
Serratura  
Lock  
Cerradura

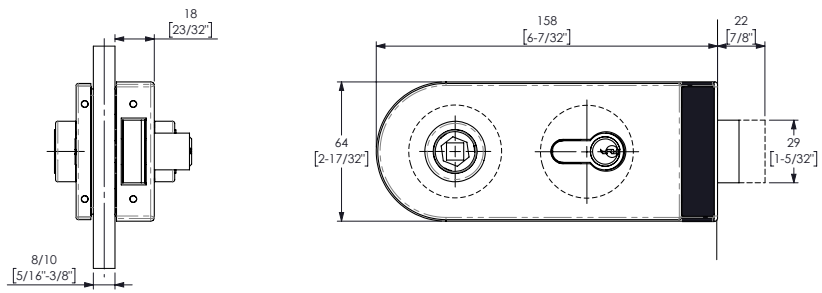

**!** Cilindro suggerito 19143 (non incluso)  
Suggested cylinder 19143 (not included)  
Cilindro aconsejado 19143 (no incluido)



**Claustra | 15910**  
Serratura magnetica  
Magnetic lock  
Cerradura magnetica

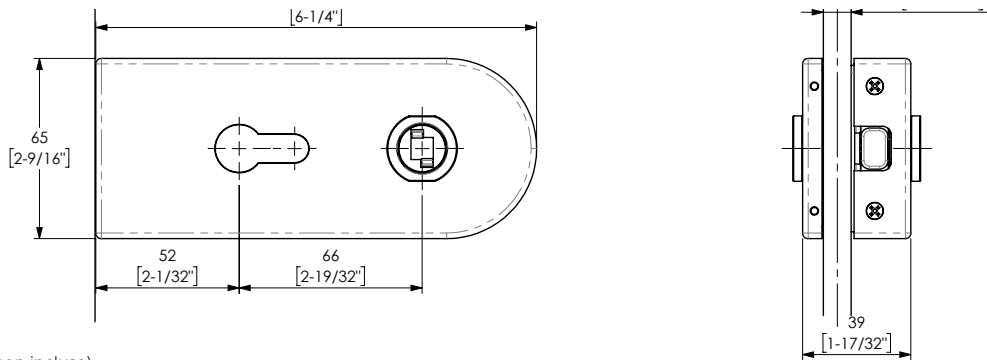

**!** Cilindro suggerito 19143 (non incluso)  
Suggested cylinder 19143 (not included)  
Cilindro aconsejado 19143 (no incluido)



**Quadra | 15912**  
Serratura magnetica  
Magnetic lock  
Cerradura magnetica

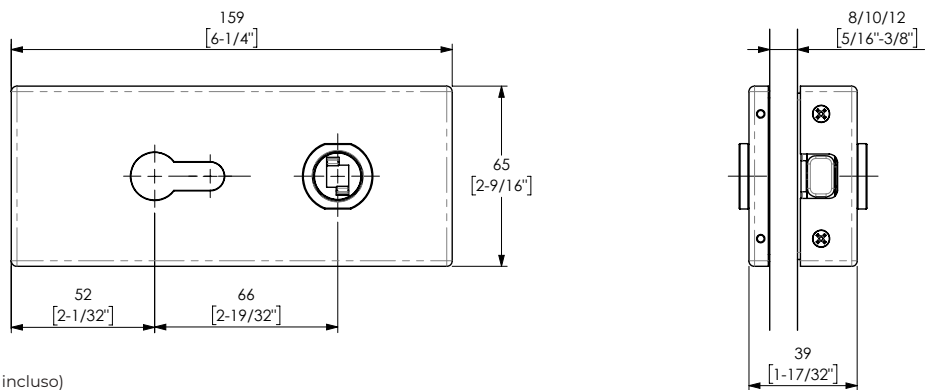

**!** Cilindro suggerito 19143 (non incluso)  
Suggested cylinder 19143 (not included)  
Cilindro aconsejado 19143 (no incluido)

**Quadra-Claustra | 15916**  
Piastrina per serratura ma-  
gnetica  
Strike plate for magnetic lock  
Chapa para cerradura ma-  
gnetica

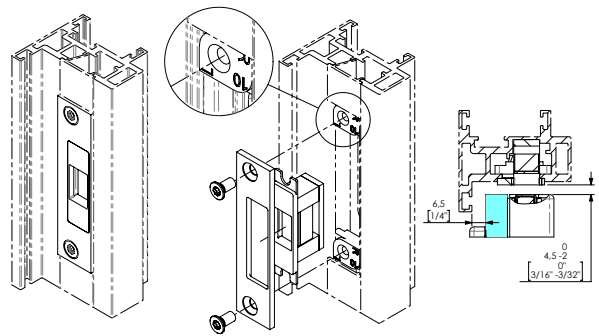

**!** Richiede lavorazione del montante  
Frame working requested  
Requiere elaboración de extrusión



Tabula



Spessore vetro  
Glass thickness  
Espesor del vidrio  
**8 ÷ 12,5 mm\***  
5/32"+5/32"\*

\*Ulteriori spessori su richiesta  
\*More thicknesses upon request  
\*Más espesores bajo pedido



Portata  
Weight  
Peso  
**100 kg**  
247,50 Lbs



Larghezza anta  
Max. door width  
Max. ancho de la puerta  
**550 ÷ 1200 mm**  
21 21/32"÷47 1/4"



EN1527  
100.000 cicli  
100.000 cycles  
100.000 ciclos



Max. altezza anta  
Max. door width  
Max. altura de la puerta

**3000 mm\***  
118 7/64" \*

\*Ulteriori altezze su richiesta  
\*More heights upon request  
\*Más alturas bajo pedido

**Finiture standard  
Standard finishes  
Acabados estándar**

- 611**  
Alluminio anodizzato naturale  
Silver anodized aluminum  
Aluminio anodizado natural
- 620**  
Alluminio anodizzato nero  
Black anodized aluminum  
Aluminio anodizado negro

 SOFT CLOSE Soft close	Singolo soft close Single soft close Unico soft close	Doppio soft close Double soft close Doble soft close
 Larghezza min. anta Min. door width	<b>665 mm</b> 26 3/16"	<b>1050 mm</b> 41 11/32"

	Installazione a soffitto Ceiling installation Instalación a techo	Installazione a parete Wall installation Instalación a pared	Installazione a soffitto con fisso Ceiling installation with sidelight Instalación a techo con vidrio fijo	Installazione a parete con falso soffitto False ceiling installation Instalación a pared con falso techo	Installazione a vetro Sidelight installation Instalación con vidrio lateral
<b>Profilo porta 1</b> Door profile 1 Perfil puerta 1	✓	✓	✗	✓	✓
<b>Profilo porta 2</b> Door profile 2 Perfil puerta 2	✓	✓	✓	✗	✓

# Sistemi Systems | Sistemas

## Profilo porta 1

Door profile 1 | Perfil puerta 1

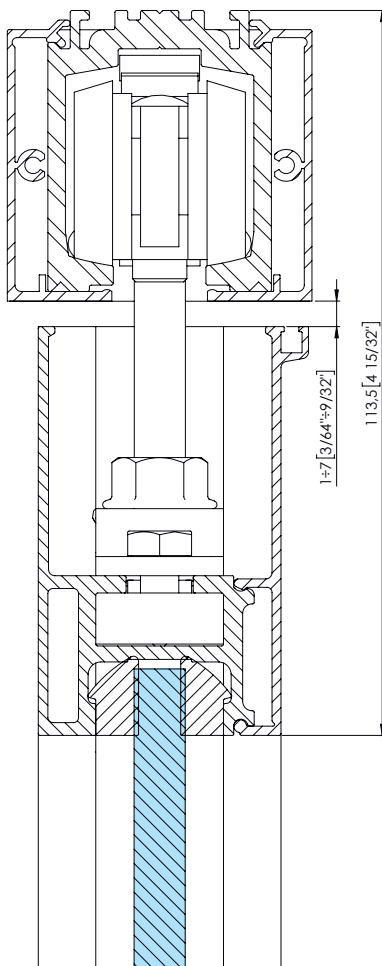

## Profilo porta 2

Door profile 2 | Perfil puerta 2

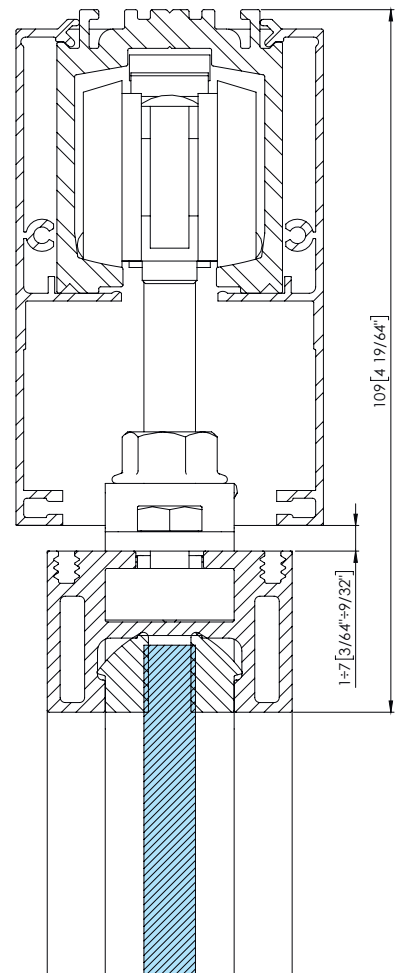

# Profilo porta 1

Door profile 1 | Perfil puerta 1

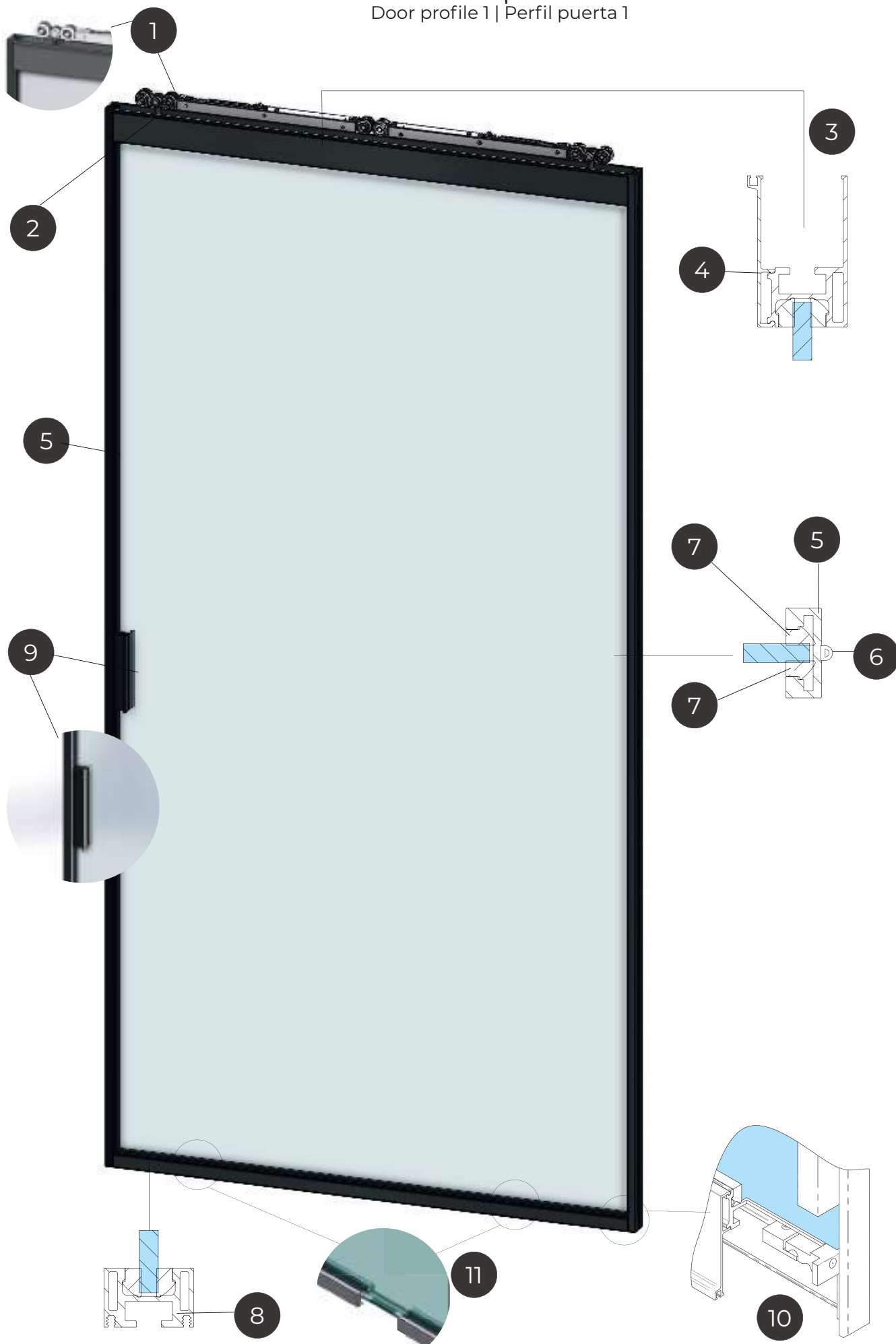

# Profilo porta 1

## Door profile 1 | Perfil puerta 1

<b>1</b>	<p><b>TB12A</b></p> <p>Kit 2 carrelli + 2 fermi clip Kit 2 door rollers+2 clip stops Kit 2 ruedas de guya+ 2 stops clip</p>	<p><b>TB13A</b></p> <p>Kit 1 carrello + 1 fermo clip +1 soft close Kit 1 door roller+1 clip stop + 1 soft close Kit 1 rueda de guya+ 1 stops clip +1 soft close</p>	<p><b>TB14A</b></p> <p>KIT 2 soft close 2 soft closes 2 soft close</p>		
<b>2</b>	<p><b>TB15A</b></p> <p>Kit 2 agganci anta Door rollers fixing kit Kit de agarre piezas correderas</p>				
<b>3</b>	<p><b>TB21A</b></p> <p>Traversa Track Traversaño</p>				
<b>4</b>	<p><b>TB22A</b></p> <p>Copertina traversa Cover for track Tapa para traversaño</p>	<p><b>TB22A</b></p> <p>Copertina traversa Cover for track Tapa para traversaño</p>	<p><b>TB20A</b></p> <p>Spazzola a infilare Brush gasket for door profile Junta de cepillo</p>		
<b>5</b>	<p><b>TB05A</b></p> <p>Montante Door frame Montante</p>	<p><b>TB06A</b></p> <p>Montante con cava per accessori Door frame with accessories gr. Montante con hueca</p>	<p><b>TB20A</b></p> <p>Spazzola a infilare Brush gasket for door profile Junta de cepillo</p>	<p><b>TB06A</b></p> <p>Montante con cava per accessori Door frame with accessories gr. Montante con hueca</p>	<p><b>TB09A</b></p> <p>Rotolo guarnizione tenuta Roll of gasket Rollo de junta para insertar</p>
<b>6</b>	<p><b>TB10A</b></p> <p><b>i</b> Opzionale   Optional   Opcional</p> <p>Guarnizione adesiva di testa Head gasket to be glued Junta a pegar</p>				
<b>7</b>	<p><b>TB08A</b></p> <p>Rotolo di guarnizione ferma-vetro Roll of gasket for glass fixing Rollo de junta para vidrio</p>				
<b>8</b>	<p><b>TB07A</b></p> <p>Traversa con cava per accessori Traverse with accessories groove Traversaño con hueca</p>	<p><b>TB07A</b></p> <p>Traversa con cava per accessori Traverse with accessories groove Traversaño con hueca</p>	<p><b>TB20A</b></p> <p>Spazzola a infilare Brush gasket for door pr. Junta de cepillo</p>	<p><b>TB07A</b></p> <p>Traversa con cava per accessori Traverse with accessories groove Traversaño con hueca</p>	<p><b>TB09A</b></p> <p>Rotolo guarnizione tenuta Roll of gasket Rollo de junta para insertar</p>
<b>9</b>	<p><b>TB17A</b></p> <p>Kit maniglie per anta scorrevole a incollare 4 handles to glue for sliding system Kit manetas a pegar para puerta corredera</p>	<p><b>TB99A</b></p> <p>Coppia di maniglie a incollare Pair of handles to glue Par de manetas para pegar</p>			
<b>10</b>	<p><b>TB16A</b></p> <p>Kit 4 angoli telaio 4 Corner door frame kit Kit 4 esquinas marco de puerta</p>	<p style="text-align: center;"><b>11</b></p> <p><b>TB19A</b></p> <p>Coppia di spessori per supporto vetro Pair of glass supports Par de soportes para vidrio</p>			

# Profilo porta 2

Door profile 2 | Perfil puerta 2

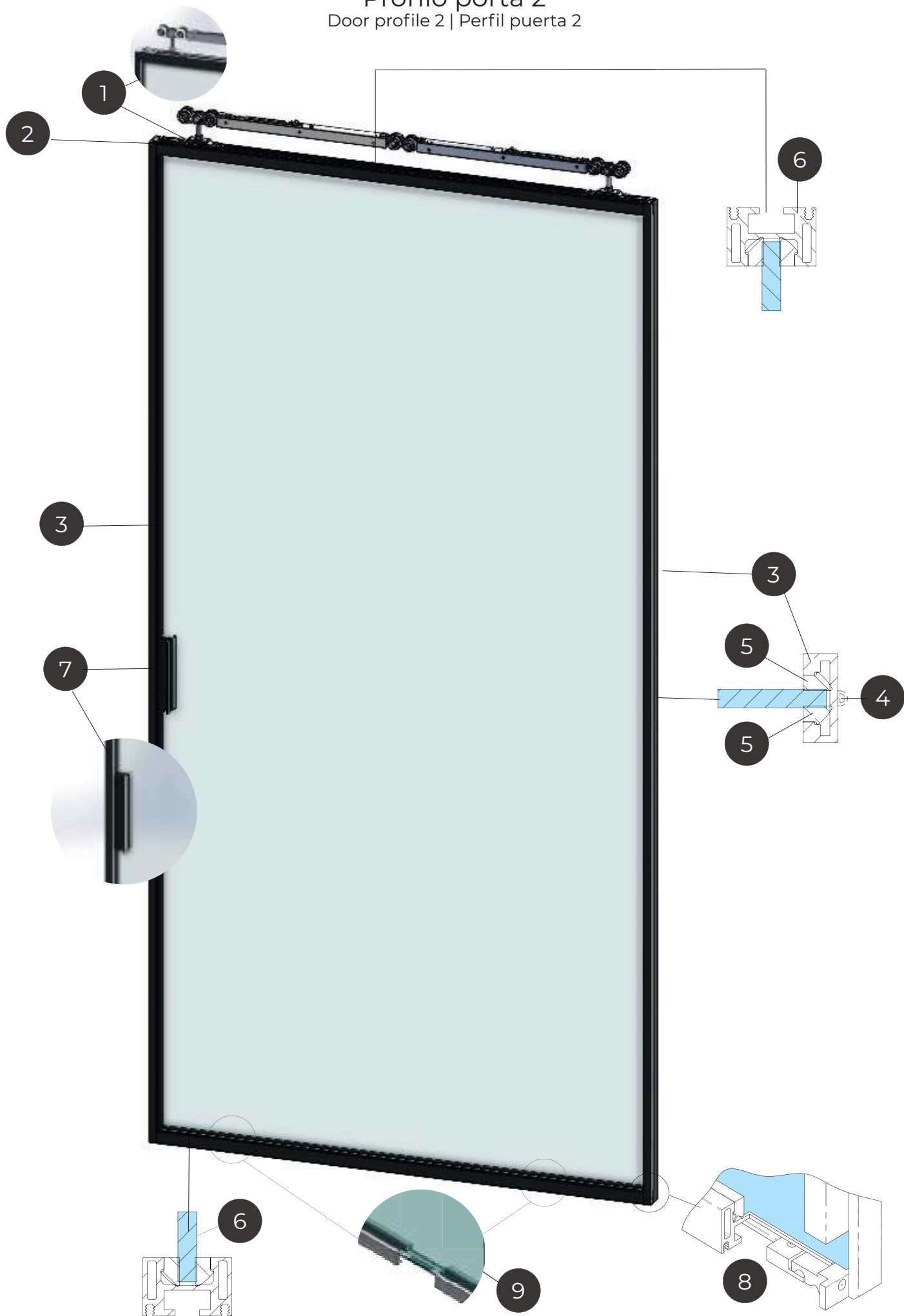

# Profilo porta 2

## Door profile 2 | Perfil puerta 2

1

**TB12A**

Kit 2 carrelli + 2 fermi clip  
Kit 2 door rollers+2 clip stops  
Kit 2 ruedas de guya+ 2 stops clip

**TB13A**

Kit 1 carrello + 1 fermo clip +1 soft close  
Kit 1 door roller+1 clip stop + 1 soft close  
Kit 1 rueda de guya+ 1 stops clip +1 soft close

**TB14A**

KIT 2 soft close  
2 soft closes  
2 soft close

2

**TB15A**

Kit 2 agganci anta  
Door rollers fixing kit  
Kit de agarre piezas correderas

3

**TB05A**

Montante  
Door frame  
Perfil

**TB06A**

Montante con cava per accessori  
Door frame with accessories groove  
Montante con hueca

**TB20A**

Spazzola a infilare  
Brush gasket for door profile  
Junta de cepillo

**TB06A**

Montante con cava per accessori  
Door frame with accessories groove  
Montante con hueca

**TB09A**

Rotolo guarnizione tenuta  
Roll of gasket  
Rollo de junta para insertar

4

**TB10A** ⓘ Opzionale | Optional | Opcional

Guarnizione adesiva di testa  
Head gasket to be glued  
Junta a pegar

5

**TB08A**

Rotolo di guarnizione ferma-vetro  
Roll of gasket for glass fixing  
Rollo de junta para vidrio

6

**TB07A**

Traversa con cava per accessori  
Traverse with accessories groove  
Traversaño con hueca

**TB07A**

Traversa con cava per accessori  
Traverse with accessories groove  
Traversaño con hueca

**TB20A**

Spazzola a infilare  
Brush gasket for door profile  
Junta de cepillo

**TB07A**

Traversa con cava per accessori  
Traverse with accessories groove  
Traversaño con hueca

**TB09A**

Rotolo guarnizione tenuta  
Roll of gasket  
Rollo de junta para insertar

7

**TB17A**

Kit maniglie per anta scorrevole a incollare  
Kit handles to glue for sliding system  
Kit manetas a pegar para puerta corredera

**TB99A**

Kit maniglie per anta scorrevole a incollare a tutta altezza  
Full height kit handles to glue for sliding system  
Kit manetas a pegar para puerta corredera de altura completa

8

**TB16A**

Kit 4 angoli telaio  
4 Corner door frame kit  
Kit 4 esquinas marco de puerta

9

**TB19A**

Coppia di spessori per supporto vetro  
Pair of glass supports  
Par de soportes para vidrio

# Configurazioni

## Configurations | Configuraciones

### Applicazione a soffitto

Sliding on ceiling  
Instalación de corredera a techo

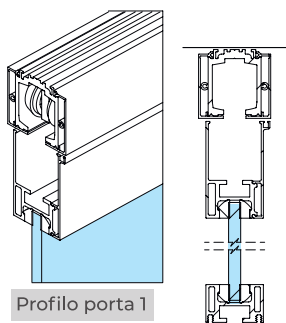
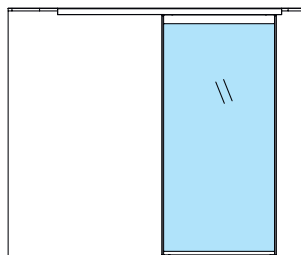

Profilo porta 1

Door profile 1 | Perfil puerta 1

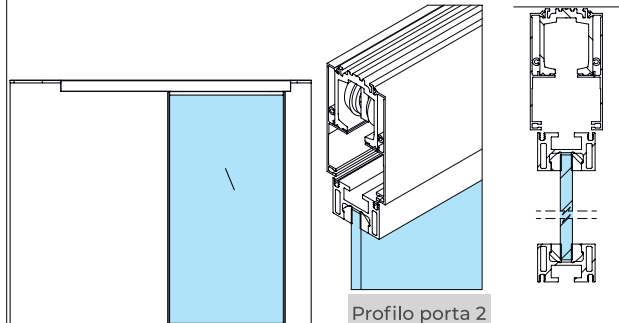

Profilo porta 2

Door profile 2 | Perfil puerta 2

### Applicazione a parete

Sliding on wall  
Instalación de corredera a pared

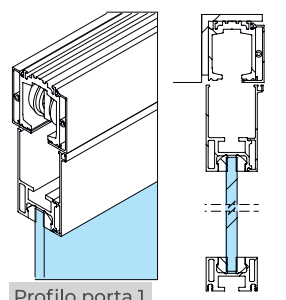
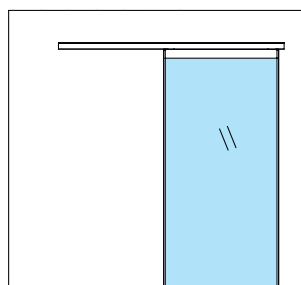

Profilo porta 1

Door profile 1 | Perfil puerta 1

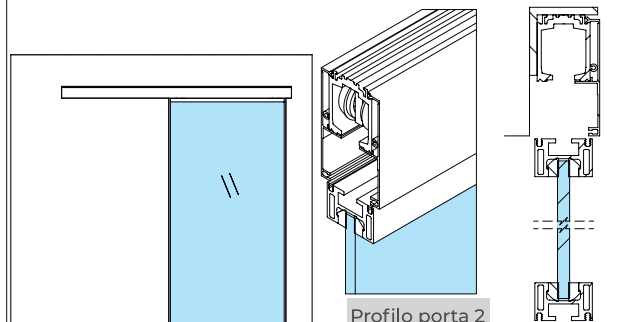

Profilo porta 2

Door profile 2 | Perfil puerta 2

### Applicazione a soffitto con vetro fisso

Sliding on ceiling with sidelight  
Instalación de corredera a techo con vidrio fijo

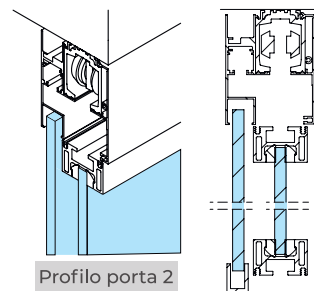
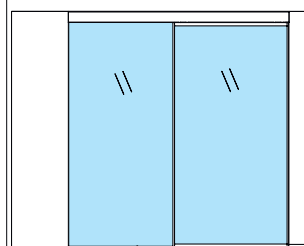

Profilo porta 2

Door profile 2 | Perfil puerta 2

### Applicazione a falso soffitto

Sliding on false ceiling  
Instalación de corredera a pared con falso techo

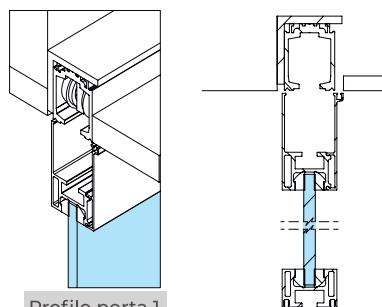
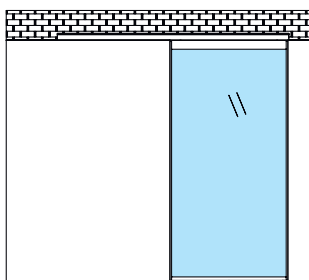

Profilo porta 1

Door profile 1 | Perfil puerta 1



### Applicazione su vetro

Sliding on sidelight  
Instalación de corredera con vidrio lateral

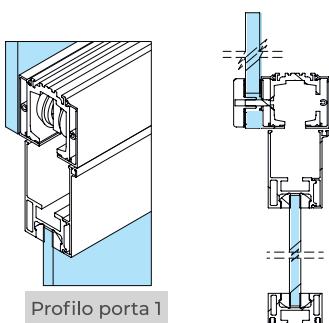
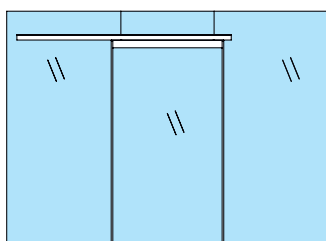

Profilo porta 1

Door profile 1 | Perfil puerta 1

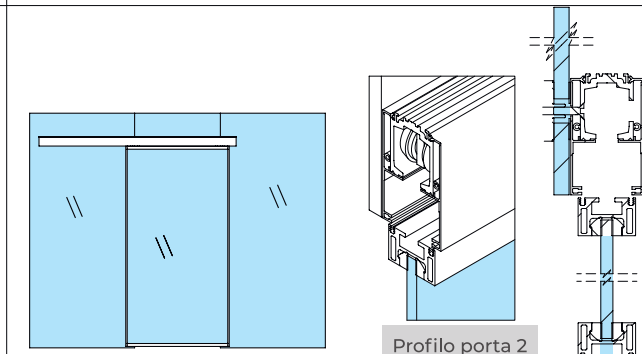

Profilo porta 2

Door profile 2 | Perfil puerta 2

# Configurazioni e dimensioni

## Configurations and dimensions | Configuraciones y dimensiones

### Applicazione a soffitto

#### Profilo porta 1

Sliding on ceiling | Door profile 1  
 Instalación de corredera a techo | Perfil puerta 1

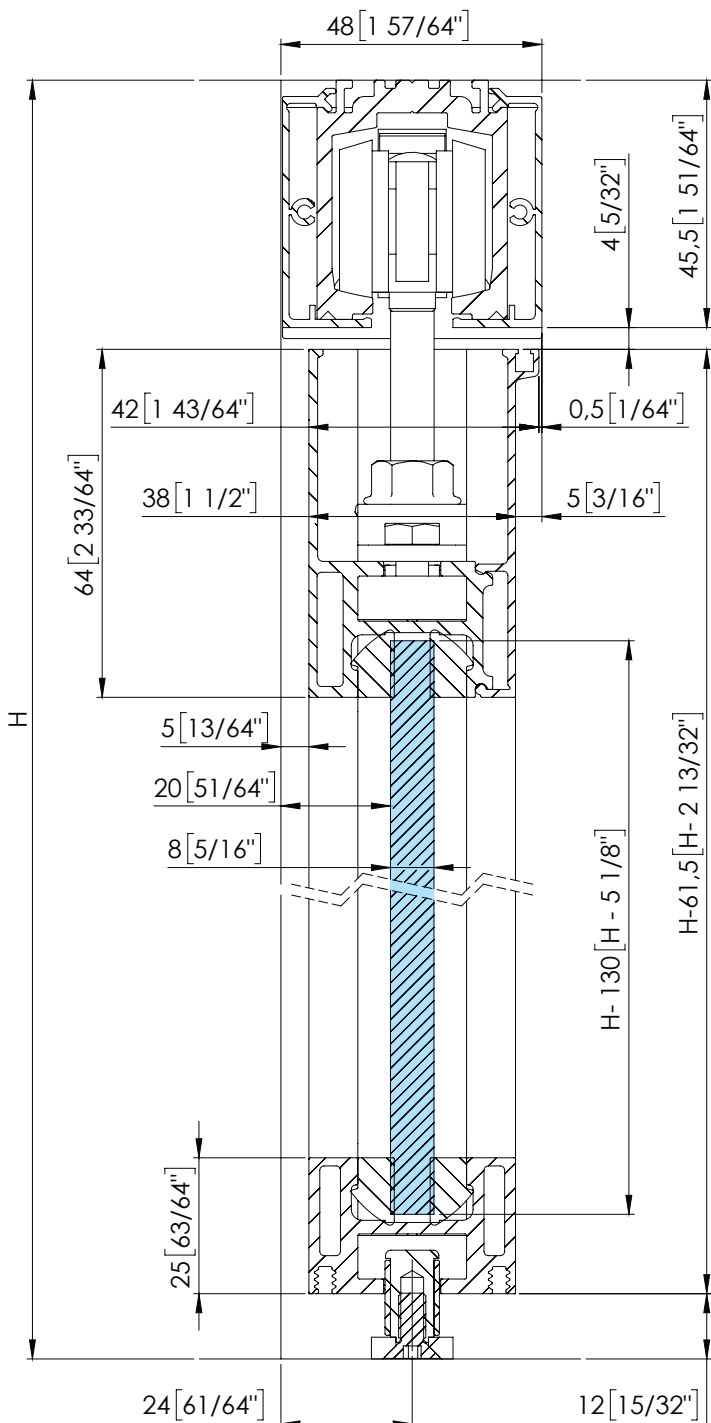

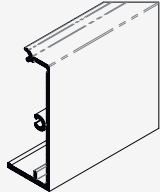
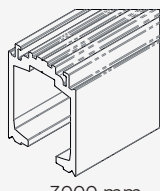
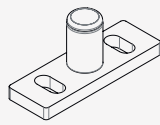
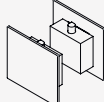
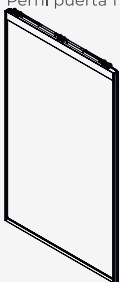
2 x	2 x	<b>TB02A</b>  3000 mm 118" 7/64 6000 mm 236" 7/32
1 x	1 x	<b>TB01A</b>  3000 mm 118" 7/64 6000 mm 236" 7/32
1 x	2 x	<b>TB18A</b> 
1 x	1 x	<b>TB23A</b> 
1 x	2 x	<b>TELAIO 1</b> Door profile 1 Door profile 1 Perfil puerta 1 

### Calcolo larghezza | Width calculation | Cálculos ancho

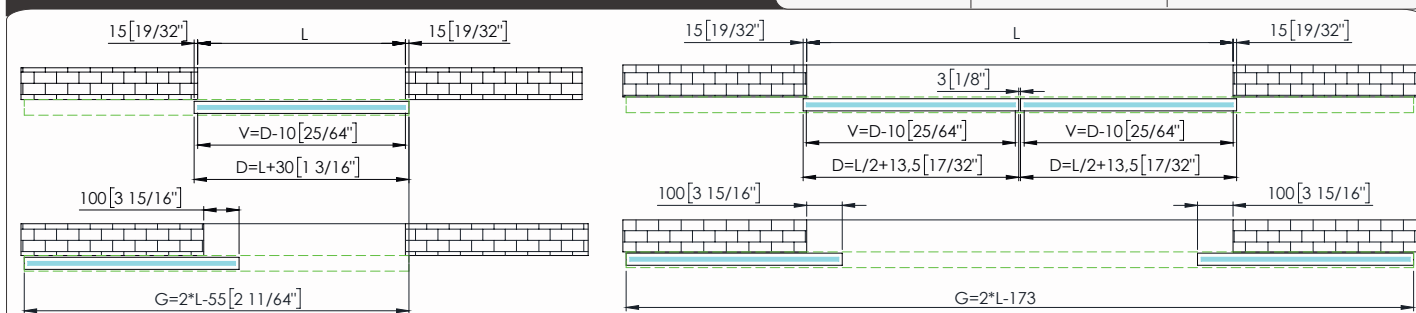

# Configurazioni e dimensioni

Configurations and dimensions | Configuraciones y dimensiones

## Applicazione a soffitto

### Profilo porta 2

Sliding on ceiling | Door profile 2  
 Instalación de corredera a techo | Perfil puerta 2

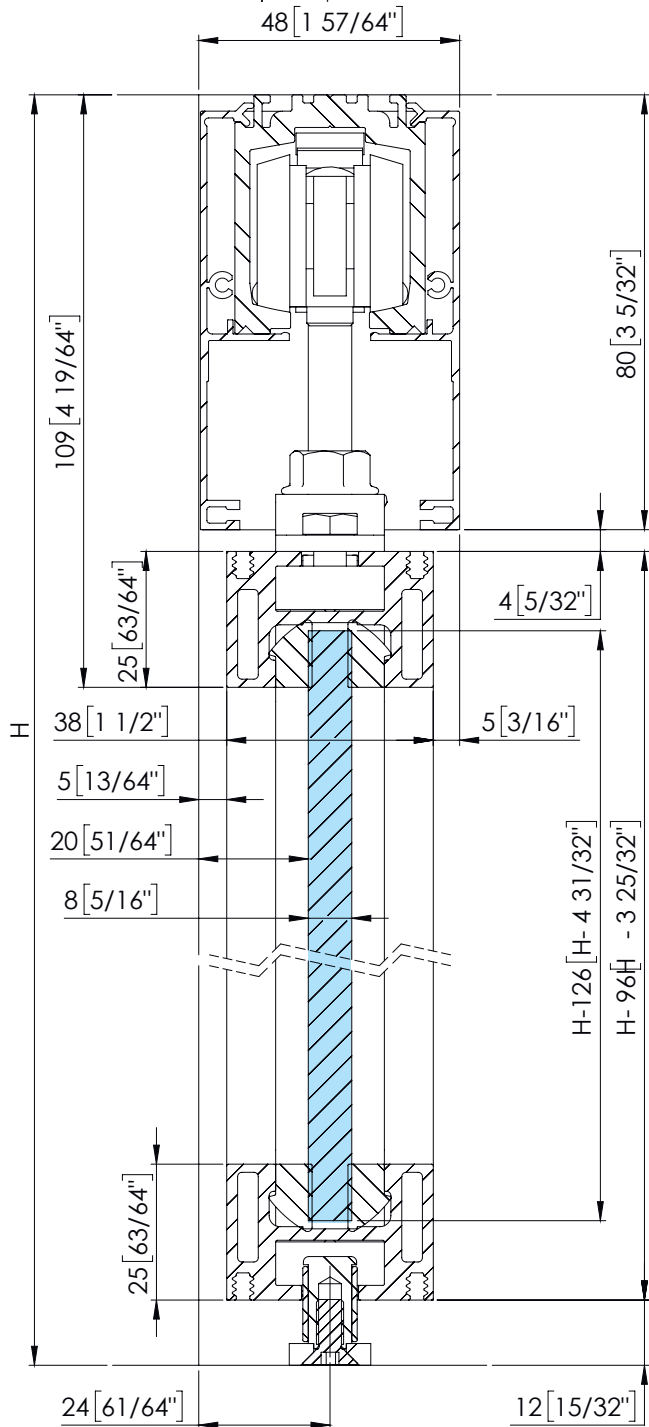

2x	2x	<b>TB03A</b>  3000 mm 118" 7/64 6000 mm 236" 7/32
1x	1x	<b>TB01A</b>  3000 mm 118" 7/64 6000 mm 236" 7/32
1x	2x	<b>TB18A</b> 
1x	1x	<b>TB24A</b> 
1x	2x	<b>TELAIO 2</b> Door profile 2 Door profile 2 Perfil puerta 2 

### Calcolo larghezza | Width calculation | Cálculos ancho

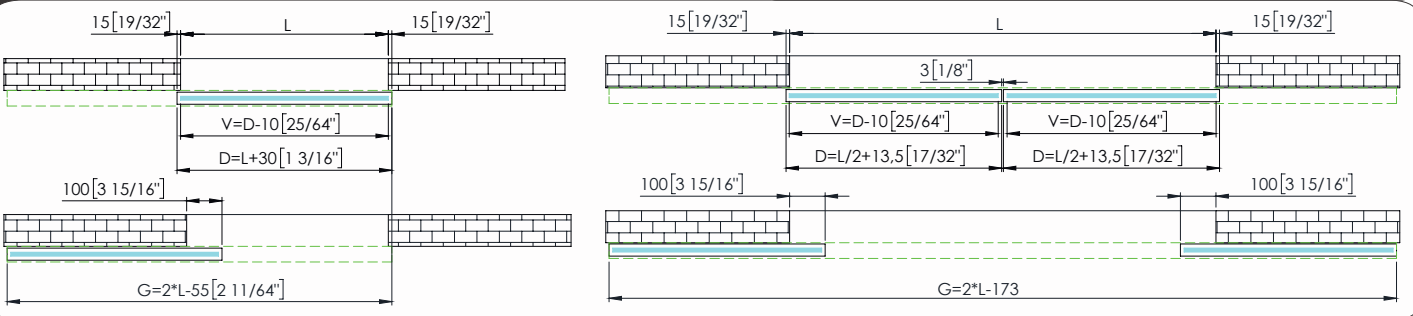

# Configurazioni e dimensioni



## Configurations and dimensions | Configuraciones y dimensiones

### Applicazione a parete

#### Profilo porta 1

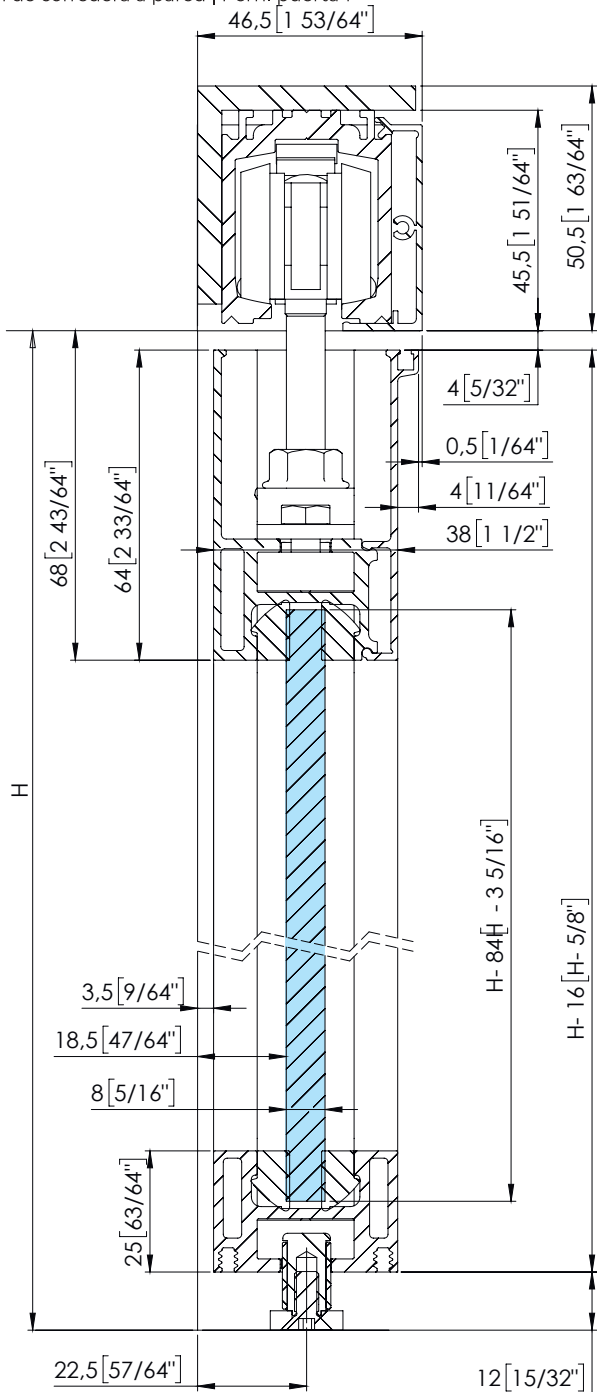
Sliding on wall | Door profile 1  
 Instalación de corredera a pared | Perfil puerta 1

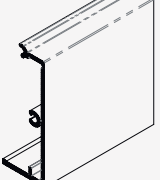
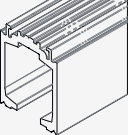
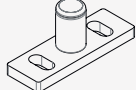

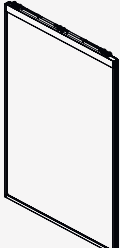
Anta singola Single door Puerta única	Anta doppia Double door Puerta doble	
1 x	1 x	<b>TB02A</b>  3000 mm 118" 7/64 6000 mm 236" 7/32
1 x	1 x	<b>TB01A</b>  3000 mm 118" 7/64 6000 mm 236" 7/32
1 x	2 x	<b>TB18A</b> 
1 x	1 x	<b>TB11A</b> 
1 x	1 x	<b>TB25A</b>  <b>i</b> Opzionale   Optional   Opcional
1 x	2 x	<b>TELAIO 1</b> Door profile 1 Perfil puerta 1 

### Calcolo larghezza | Width calculation | Cálculos ancho

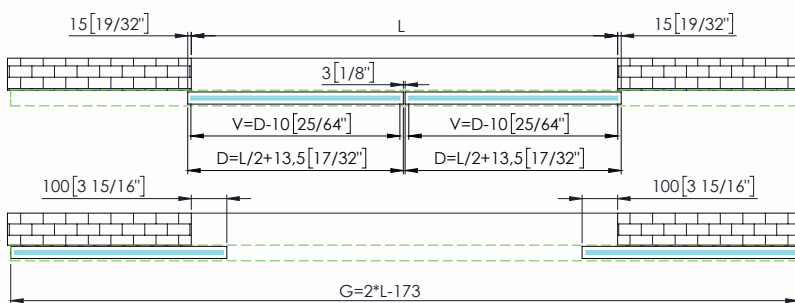
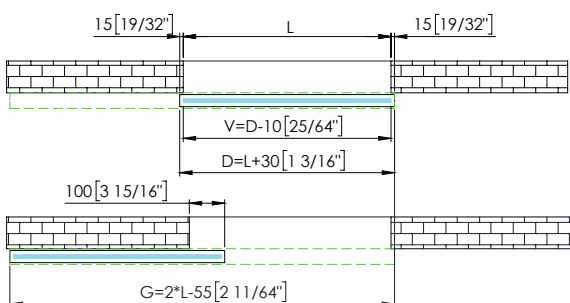

# Configurazioni e dimensioni

## Configurations and dimensions | Configuraciones y dimensiones

### Applicazione a parete

#### Profilo porta 2

Sliding on wall | Door profile 2  
 Instalación de corredera a pared | Perfil puerta 2

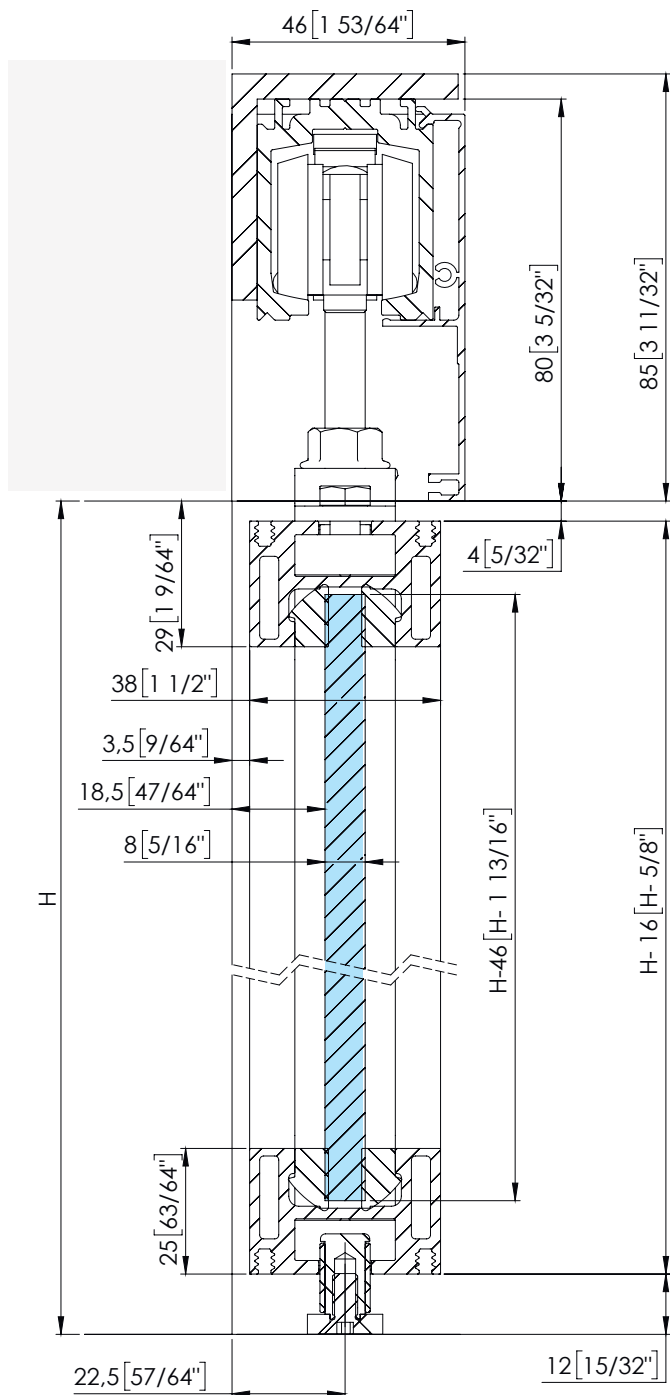

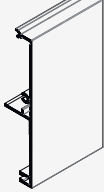
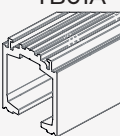
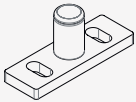
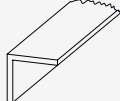
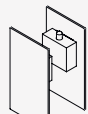
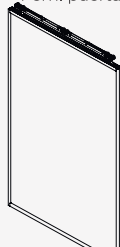
1 x	1 x	<b>TB03A</b>  3000 mm 118" 7/64 6000 mm 236" 7/32
1 x	1 x	<b>TB01A</b>  3000 mm 118" 7/64 6000 mm 236" 7/32
1 x	2 x	<b>TB18A</b> 
1 x	1 x	<b>TB11A</b> 
1 x	1 x	<b>TB26A</b>  ⓘ Opzionale   Optional   Opcional
1 x	2 x	<b>TELAIO 2</b> Door profile 2 Perfil puerta 2 

#### Calcolo larghezza | Width calculation | Cálculos ancho

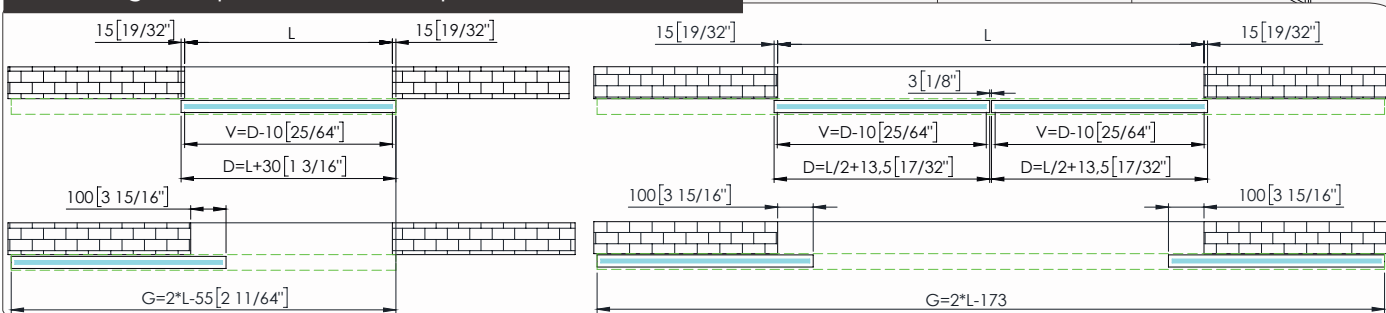

# Configurazioni e dimensioni





## Configurations and dimensions | Configuraciones y dimensiones

Applicazione a soffitto con vetro fisso

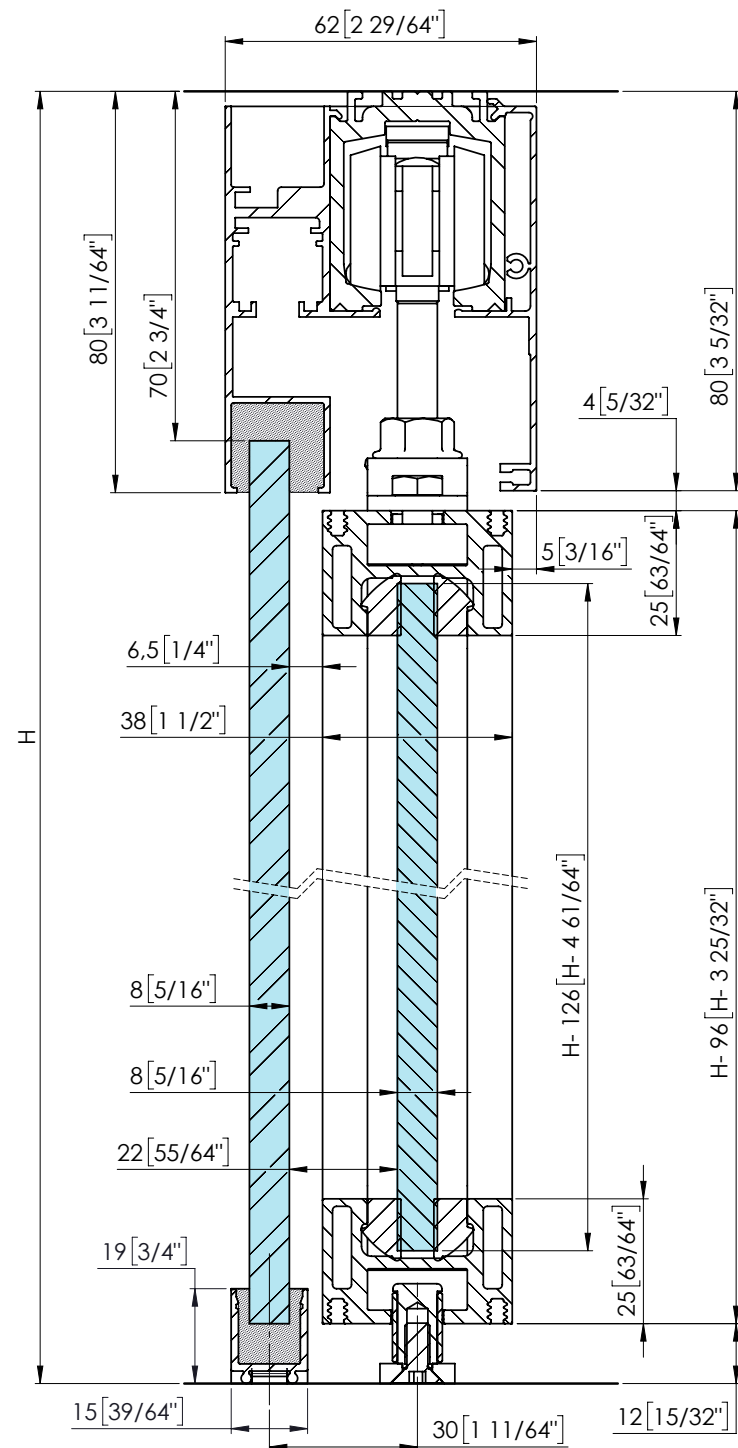
Profilo porta 2

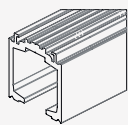
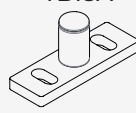
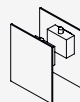
Sliding on ceiling with sidelight | Door profile 2  
 Instalación de corredera a techo con vidrio fijo | Perfil puerta 2



1 x	1 x	<b>TB03A</b>  3000 mm 118" 7/64 6000 mm 236" 7/32
1 x	1 x	<b>TB01A</b>  3000 mm 118" 7/64 6000 mm 236" 7/32
1 x	2 x	<b>TB18A</b> 
1 x	1 x	<b>TB27A</b>  i Opzionale   Optional   Opcional
1 x	1 x	<b>TB04A</b> 
1 x	2 x	<b>TELAIO 2</b> Door profile 2 Perfil puerta 2 
i Quantità da definire in base al nr di vetri fissi. Quantity based on the number of panels. Cantidad definible en función del número de vidrios fijos.		<b>TBB2A</b>  <b>TB33A</b> 

### Calcolo larghezza | Width calculation | Cálculos ancho

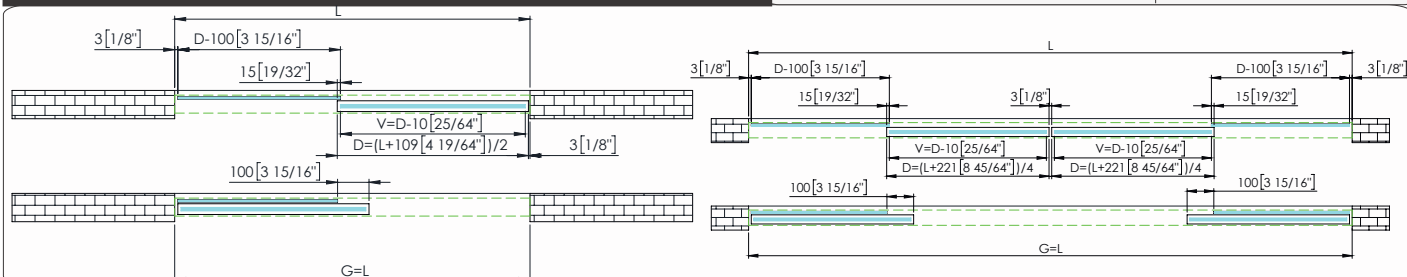

# Configurazioni e dimensioni



## Configurations and dimensions | Configuraciones y dimensiones

### Applicazione a falso soffitto

#### Profilo porta 1

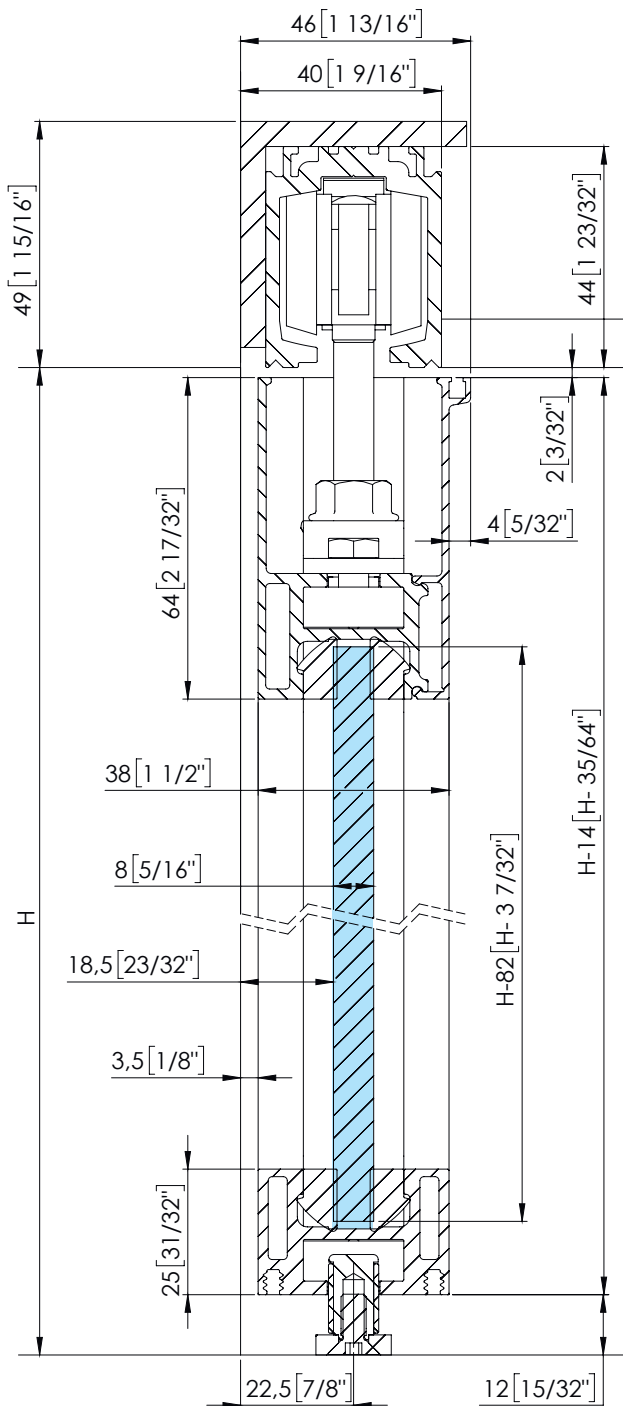
Sliding on false ceiling | Door profile 1  
 Instalación de corredera a pared con falso techo | Perfil puerta 1

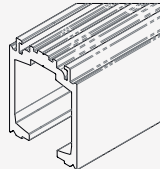
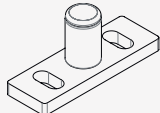
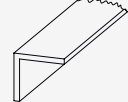
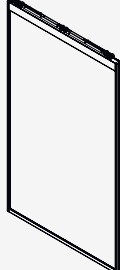

 Anta singola Single door Puerta única		 Anta doppia Double door Puerta doble		
1 x		1 x		<b>TB01A</b>  3000 mm 118" 7/64 6000 mm 236" 7/32
1 x		2 x		<b>TB18A</b> 
1 x		1 x		<b>TB11A</b> 
1 x		2 x		<b>TELAIO 1</b> Door profile 1 Perfil puerta 1 

### Calcolo larghezza | Width calculation | Cálculos ancho

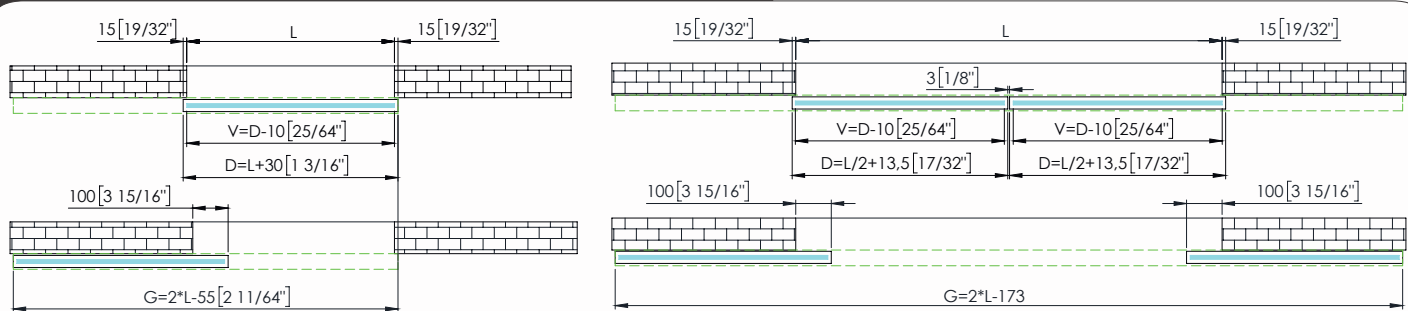

# Configurazioni e dimensioni



## Configurations and dimensions | Configuraciones y dimensiones

Applicazione su vetro fisso

Profilo porta 1

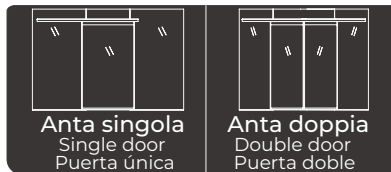
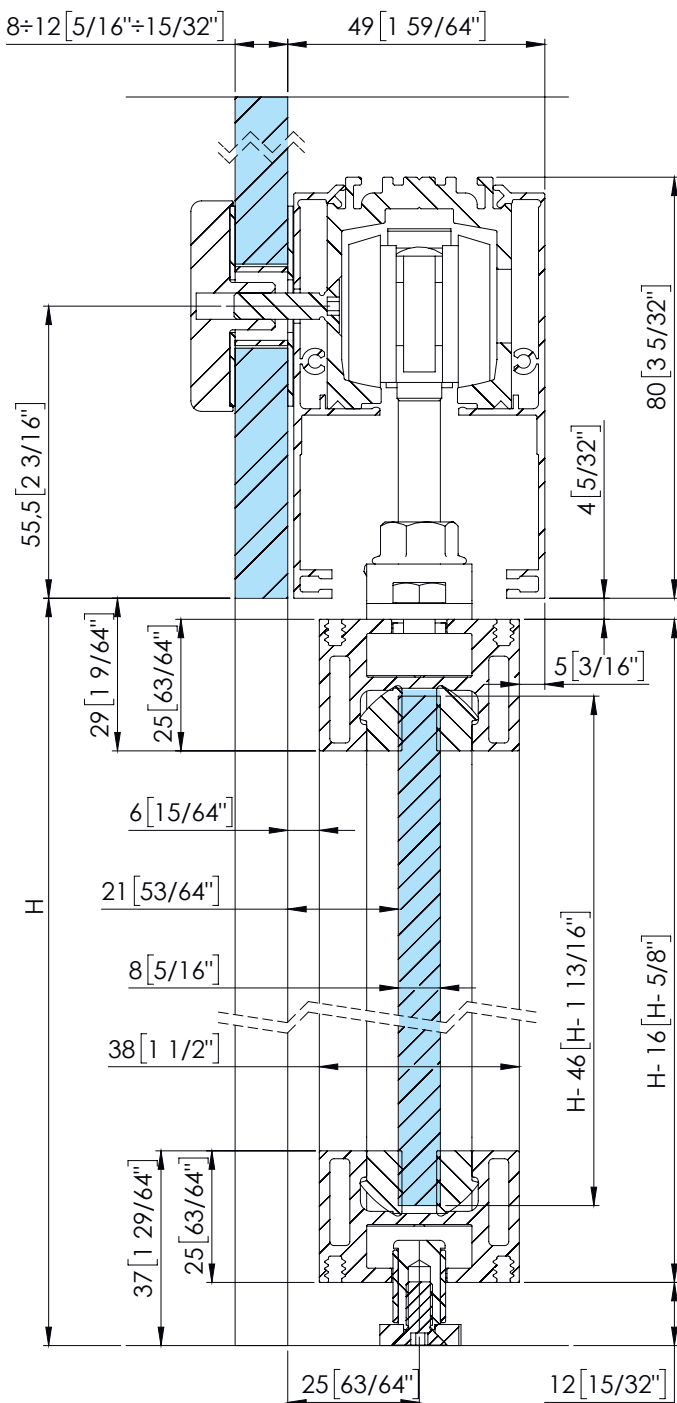
Sliding on sidelight | Door profile 1  
 Instalación de corredera a pared con falso techo | Perfil puerta 1

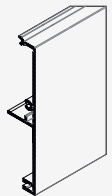
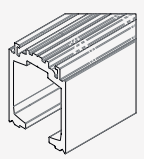
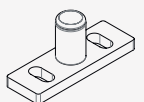
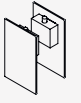

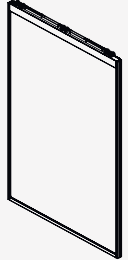
2 x	2 x	<b>TB03A</b>  3000 mm 118" 7/64 6000 mm 236" 7/32
1 x	1 x	<b>TB01A</b>  3000 mm 118" 7/64 6000 mm 236" 7/32
1 x	2 x	<b>TB18A</b> 
1 x	1 x	<b>TB24A</b>  ⓘ Opzionale   Optional   Opcional
1 x 200 mm	1 x 200 mm	<b>TB28A</b> 
1 x	2 x	<b>TELAIO 1</b> Door profile 1 Perfil puerta 1 

Calcolo larghezza | Width calculation | Cálculos ancho

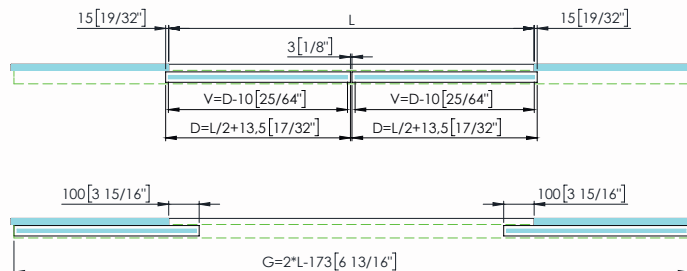
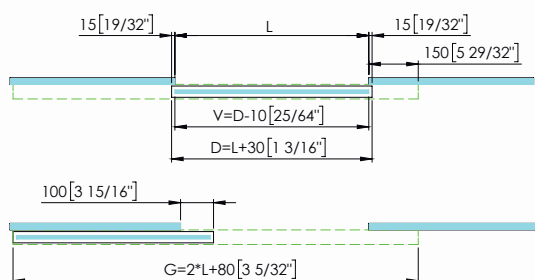

# Configurazioni e dimensioni



## Configurations and dimensions | Configuraciones y dimensiones

Applicazione su vetro fisso

Profilo porta 2

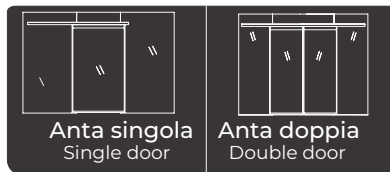
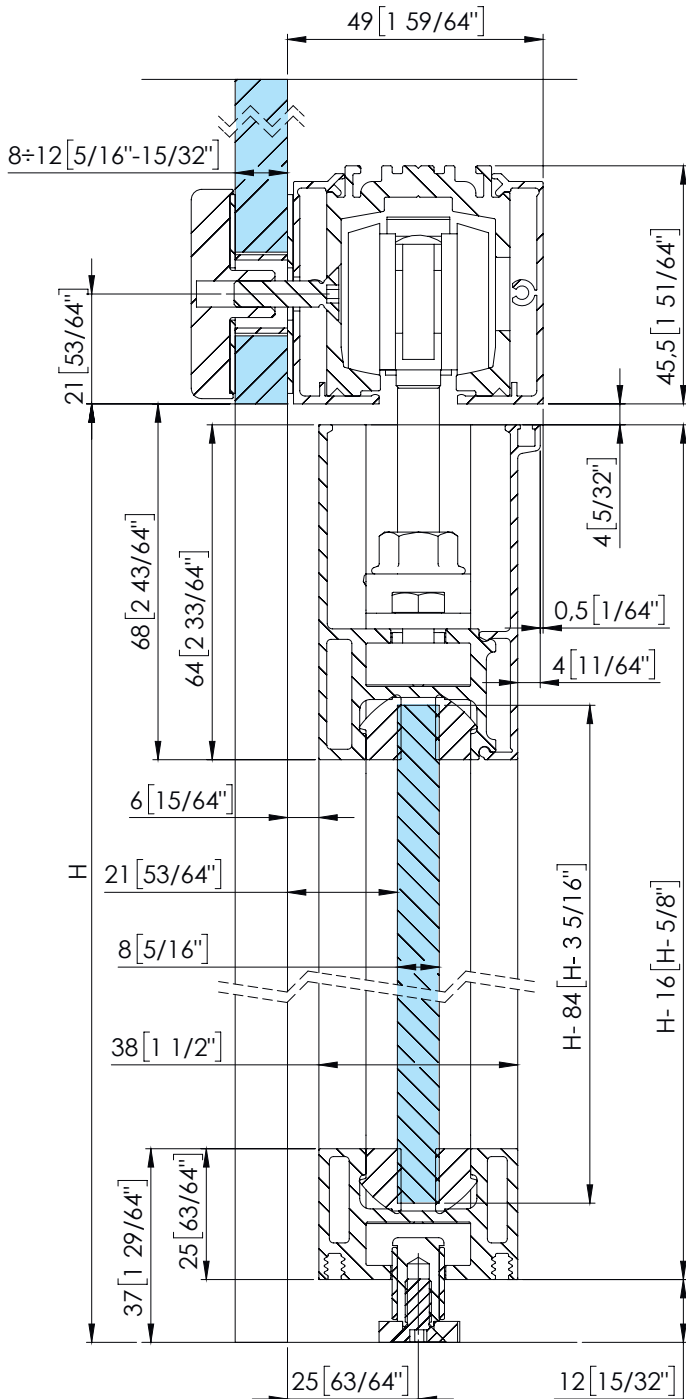
Sliding on sidelight | Door profile 2  
 Instalación de corredera con vidrio lateral | Perfil puerta 2

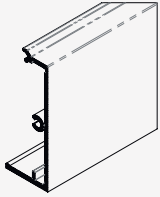
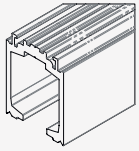
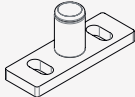

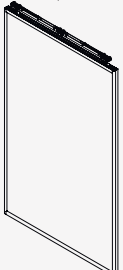
2 x	2 x	<b>TB02A</b>  3000 mm 118" 7/64 6000 mm 236" 7/32
1 x	1 x	<b>TB01A</b>  3000 mm 118" 7/64 6000 mm 236" 7/32
1 x	2 x	<b>TB18A</b> 
1 x	1 x	<b>TB23A</b>  Opzionale   Optional   Opcional
1 x 200 mm	1 x 200 mm	<b>TB28A</b> 
1 x	2 x	<b>TELAIO 2</b> Door profile 2 Perfil puerta 2 

### Calcolo larghezza | Width calculation | Cálculos ancho

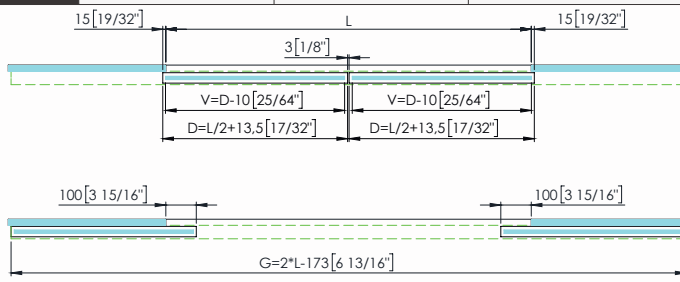
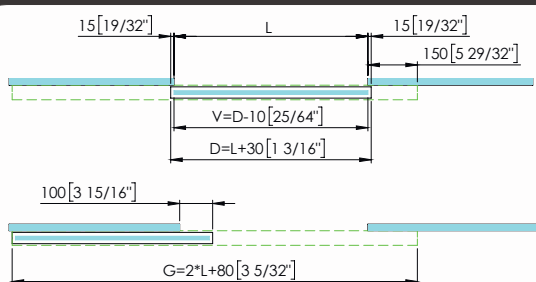

# Kit

## Kit STANDARD | TB12A

### Profilo porta 1

Kit standard | Door profile 1  
Kit estándar | Perfil puerta 1



**i** Disponibile con telaio 1  
Available with door profile 1  
Disponibile con perfil puerta 1

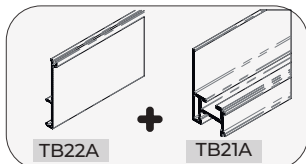

**i** Disponibile con telaio 1  
Available with door profile 1  
Disponibile con perfil puerta 1

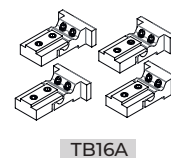
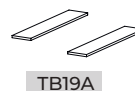
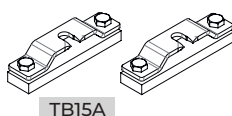
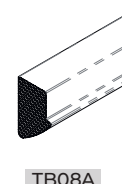
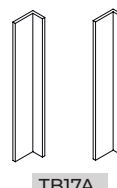
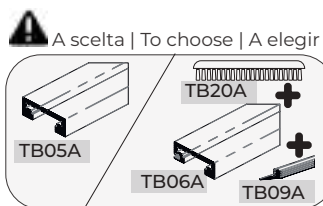
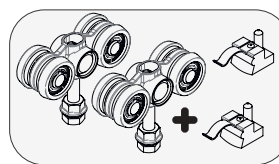
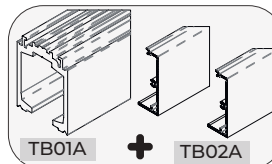

### Profilo porta 2

Kit standard | Door profile 2  
Kit estándar | Perfil puerta 1



**i** Disponibile con telaio 2  
Available with door profile 2  
Disponibile con perfil puerta 2

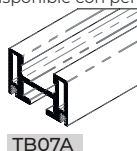

**i** Disponibile con telaio 2  
Available with door profile 2  
Disponibile con perfil puerta 2

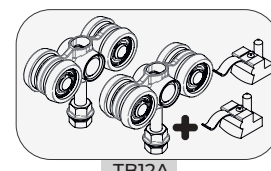
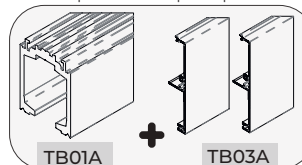

**A scelta | To be chosen | A elegir**

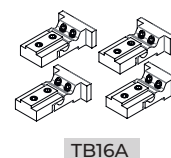
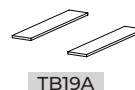
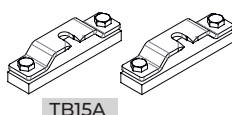
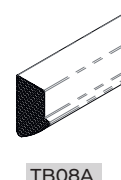
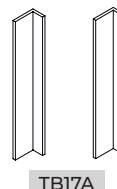
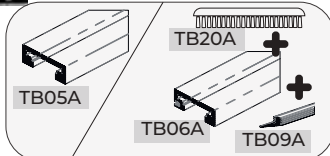

# Kit

## Kit 2 PREMIUM| TB13A

### Profilo porta 1

Kit premium | Door profile 1  
Kit premium | Perfil puerta 1



**i** Disponibile con telaio 1  
Available with door profile 1  
Disponible con perfil puerta 1

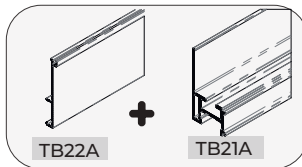

**i** Disponibile con telaio 1  
Available with door profile 1  
Disponible con perfil puerta 1

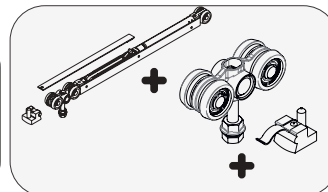
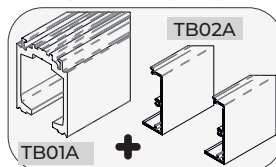

**A** A scelta | To choose | A escoger

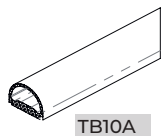
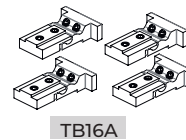
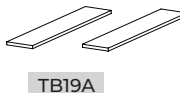
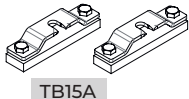
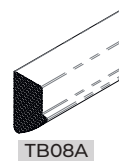
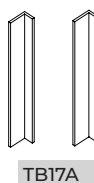
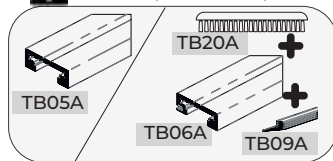

**A** A scelta | To be chosen | A escoger

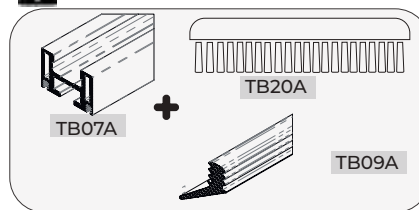

### Profilo porta 2

Kit premium | Door profile 2  
Kit premium | Perfil puerta 2



**i** Disponibile con telaio 2  
Available with door profile 2  
Disponible con perfil puerta 2

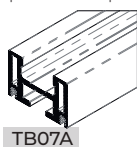

**i** Disponibile con telaio 2  
Available with door profile 2  
Disponible con perfil puerta 2

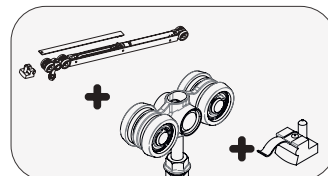
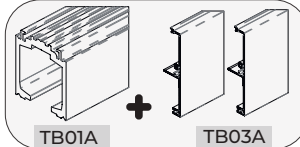

**A** A scelta | To be chosen | A escoger

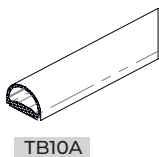
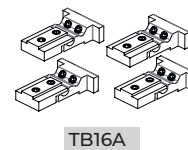
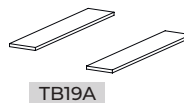
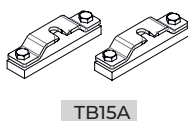
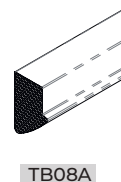
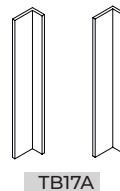
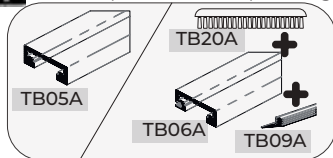

**A** A scelta | To be chosen | A escoger

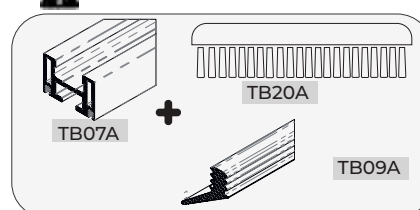

# Kit

## Kit 3 Full opt| TB14A

### Profilo porta 1

Kit full opt. | Door profile 1  
Kit completo opcional | Perfil puerta 1



**i** Disponibile con telaio 1  
Available with door profile 1  
Disponibile con perfil puerta 1

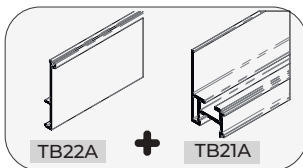

**i** Disponibile con telaio 1  
Available with door profile 1  
Disponibile con perfil puerta 1

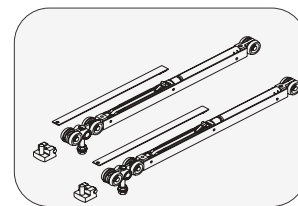
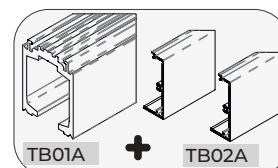

**!** A scelta | To be chosen | A escoger

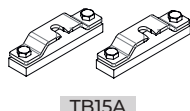
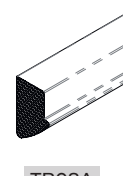
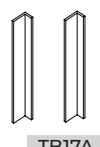
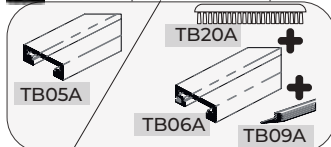

TB15A

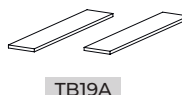

TB19A

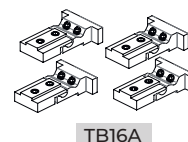

TB16A

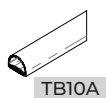

TB10A

**!** A scelta | To be chosen | A escoger

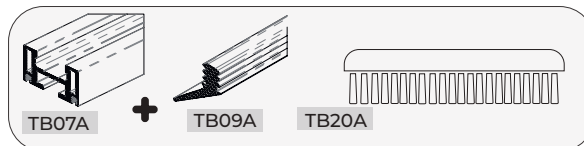

TB07A

TB09A

TB20A

### Profilo porta 2

Kit full opt. | Door profile 2  
Kit completo opcional | Perfil puerta 2



**i** Disponibile con telaio 2  
Available with door profile 2  
Disponibile con perfil puerta 2

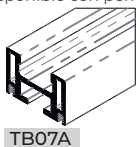

TB07A

**i** Disponibile con telaio 2  
Available with door profile 2  
Disponibile con perfil puerta 2

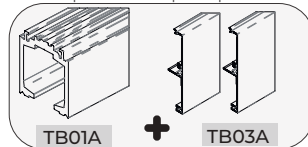

TB01A

TB03A

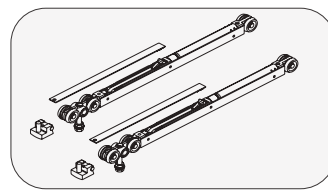

TB14A

**!** A scelta | To be chosen | A escoger

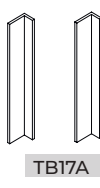
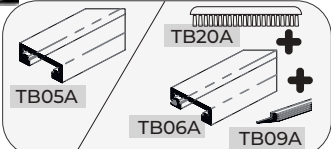

TB17A

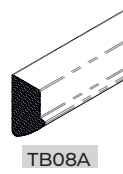

TB08A

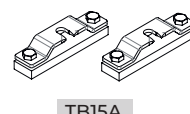

TB15A

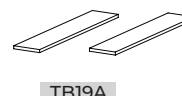

TB19A

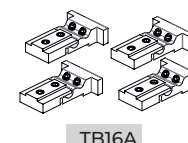

TB16A

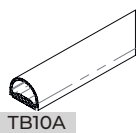

TB10A

**!** A scelta | To be chosen | A escoger

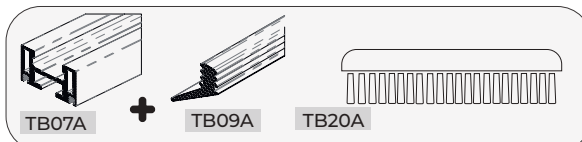

TB07A

TB09A

TB20A

## Componenti Components | Componentes

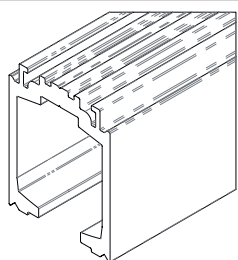

Guida per carrelli  
Rail door rollers  
Guya para carretillas



TB01A	Lunghezza   Length   Longitud
TB01A 30995	3000 mm   118"7/64
TB01A 60995	6000 mm   236" 7/32

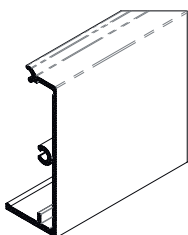

Copertina per guida Profilo porta 1  
Cover for rail Door profile 1  
Tapa para guya Perfil puerta 1



TB02A	Lunghezza   Length   Longitud
TB02A 30	3000 mm   118"7/64
TB02A 60	6000 mm   236" 7/32

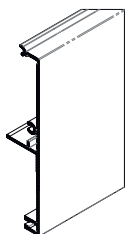

Copertina per guida Profilo porta 2  
Cover for rail Door profile 2  
Tapa para guya Perfil puerta 2



TB03A	Lunghezza   Length   Longitud
TB03A 30	3000 mm   118"7/64
TB03A 60	6000 mm   236" 7/32

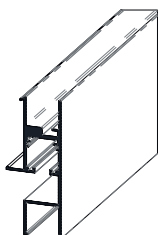

Copertina + supporto per  
vetro fisso  
Cover + stand for fixed panel  
Tapa + soporte para vidrio fijo



TB04A	Lunghezza   Length   Longitud
TB04A 30	3000 mm   118"7/64
TB04A 60	6000 mm   236" 7/32

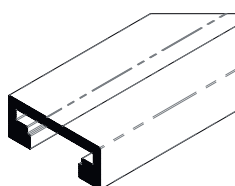

Montante  
Door frame  
Montante



TB05A	Lunghezza   Length   Longitud
TB05A 30	3000 mm   118"7/64
TB05A 60	6000 mm   236" 7/32

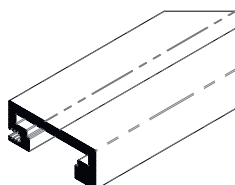

Montante con cava per accessori  
Door frame with accessories groove  
Montante con hueca



TB06A	Lunghezza   Length   Longitud
TB06A 30	3000 mm   118"7/64
TB06A 60	6000 mm   236" 7/32

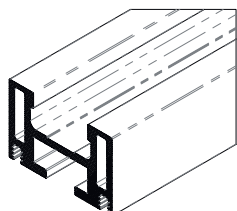

Traversea con cava per accessori  
Traverse with accessories groove  
Traverseño con hueca



TB07A	Lunghezza   Length   Longitud
TB07A 30	3000 mm   118"7/64
TB07A 60	6000 mm   236" 7/32

# Componenti

Components | Componentes

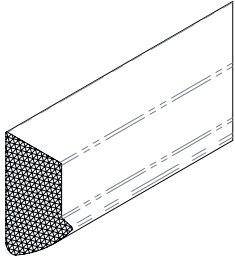
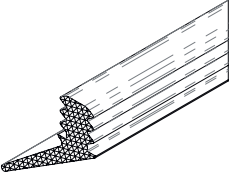
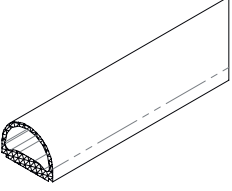
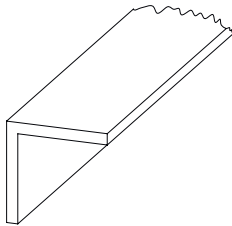
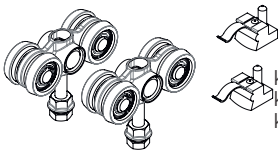
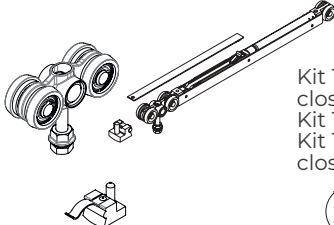
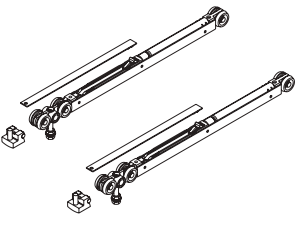
 <p>Rotolo di guarnizione per ferma-vetro Roll of gasket for glass fixing Rollo de junta para vidrio</p>	<table border="1"> <thead> <tr> <th colspan="2">TB08A</th> <th>Lunghezza   Length   Longitud</th> </tr> </thead> <tbody> <tr> <td>TB08A X1</td> <td></td> <td>15 m   590"35/64</td> </tr> <tr> <td>TB08A X2</td> <td></td> <td>25 m   984"1/4</td> </tr> <tr> <td>TB08A X3</td> <td></td> <td>35 m   1377"61/64</td> </tr> </tbody> </table>	TB08A		Lunghezza   Length   Longitud	TB08A X1		15 m   590"35/64	TB08A X2		25 m   984"1/4	TB08A X3		35 m   1377"61/64
TB08A		Lunghezza   Length   Longitud											
TB08A X1		15 m   590"35/64											
TB08A X2		25 m   984"1/4											
TB08A X3		35 m   1377"61/64											
 <p>Rotolo guarnizione tenuta Roll of gasket Rollo de junta para insertar</p>	<table border="1"> <thead> <tr> <th colspan="2">TB09A</th> <th>Lunghezza   Length   Longitud</th> </tr> </thead> <tbody> <tr> <td>TB09A 30</td> <td></td> <td>3000 mm   118"7/64</td> </tr> <tr> <td>TB09A 60</td> <td></td> <td>6000 mm   236" 7/32</td> </tr> </tbody> </table>	TB09A		Lunghezza   Length   Longitud	TB09A 30		3000 mm   118"7/64	TB09A 60		6000 mm   236" 7/32			
TB09A		Lunghezza   Length   Longitud											
TB09A 30		3000 mm   118"7/64											
TB09A 60		6000 mm   236" 7/32											
 <p>Guarnizione adesiva di testa Head gasket to be glued Junta a pegar</p>	<table border="1"> <thead> <tr> <th colspan="2">TB10A</th> <th>Lunghezza   Length   Longitud</th> </tr> </thead> <tbody> <tr> <td>TB10A 30</td> <td></td> <td>3000 mm   118"7/64</td> </tr> <tr> <td>TB10A 60</td> <td></td> <td>6000 mm   236" 7/32</td> </tr> </tbody> </table>	TB10A		Lunghezza   Length   Longitud	TB10A 30		3000 mm   118"7/64	TB10A 60		6000 mm   236" 7/32			
TB10A		Lunghezza   Length   Longitud											
TB10A 30		3000 mm   118"7/64											
TB10A 60		6000 mm   236" 7/32											
 <p>Supporto per parete Wall mounting fitting Soporte para pared</p>	<table border="1"> <thead> <tr> <th colspan="2">TB11A</th> <th>Lunghezza   Length   Longitud</th> </tr> </thead> <tbody> <tr> <td>TB11A 30</td> <td></td> <td>3000 mm   118"7/64</td> </tr> <tr> <td>TB11A 60</td> <td></td> <td>6000 mm   236" 7/32</td> </tr> </tbody> </table>	TB11A		Lunghezza   Length   Longitud	TB11A 30		3000 mm   118"7/64	TB11A 60		6000 mm   236" 7/32			
TB11A		Lunghezza   Length   Longitud											
TB11A 30		3000 mm   118"7/64											
TB11A 60		6000 mm   236" 7/32											
 <p>Kit 2 carrelli + 2 fermi clip Kit 2 door rollers+2 clip stops Kit 2 ruedas de guya+ 2 stops clip</p>	<p><b>TB12A</b></p>												
 <p>Kit 1 carrello + 1 fermo clip +1 soft close Kit 1 door roller+1 clip stop + 1 soft close Kit 1 rueda de guya+ 1 stops clip +1 soft close</p>	<p><b>TB13A</b></p>												
 <p>Kit 2 soft close Kit 2 soft closes Kit 2 soft close</p>	<p><b>TB14A</b></p>												

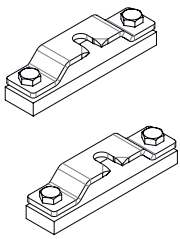
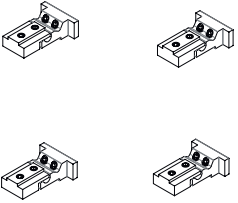
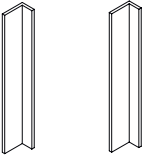
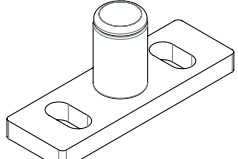
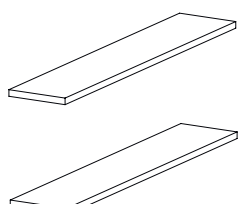
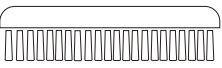
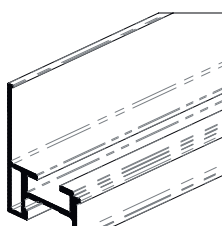

# Componenti

Components | Componentes

	<p><b>Kit 2 agganci anta</b> Door rollers fixing kit Kit de agarre piezad correderas</p>	<p><b>TB15A</b></p>									
	<p><b>Kit 4 angoli telaio</b> 4 Corner door frame kit Kit 4 esquinas marco de puerta</p>	<p><b>TB16A</b></p>									
	<p><b>Kit maniglie per anta scorrevole a incollare</b> Kit handles to glue for sliding system Kit manetas a pegar para puerta corredera</p>	<table border="1"> <thead> <tr> <th colspan="2">TB17A</th> <th>Lunghezza   Length   Longitud</th> </tr> </thead> <tbody> <tr> <td>Standard</td> <td></td> <td>150 mm</td> </tr> <tr> <td>TB98A</td> <td></td> <td>Su richiesta   Upon request</td> </tr> </tbody> </table>	TB17A		Lunghezza   Length   Longitud	Standard		150 mm	TB98A		Su richiesta   Upon request
TB17A		Lunghezza   Length   Longitud									
Standard		150 mm									
TB98A		Su richiesta   Upon request									
	<p><b>Guida a terra anta scorrevole</b> Ground slide Guía de suelo</p>	<p><b>TB18A</b></p>									
	<p><b>Coppia di spessori per supporto vetro</b> Pair of glass supports Par de soportes para vidrio</p>	<p><b>TB19A</b></p>									
	<p><b>Spazzola ad infilare</b> Brush for door frame Perfil con cepillo</p>	<table border="1"> <thead> <tr> <th colspan="2">TB20A</th> <th>Lunghezza   Length   Longitud</th> </tr> </thead> <tbody> <tr> <td>TB20A 30995</td> <td></td> <td>3000 mm   118"7/64</td> </tr> <tr> <td>TB20A 60995</td> <td></td> <td>6000 mm   236" 7/32</td> </tr> </tbody> </table>	TB20A		Lunghezza   Length   Longitud	TB20A 30995		3000 mm   118"7/64	TB20A 60995		6000 mm   236" 7/32
TB20A		Lunghezza   Length   Longitud									
TB20A 30995		3000 mm   118"7/64									
TB20A 60995		6000 mm   236" 7/32									
	<p><b>Traversa</b> Track Traversaño</p>	<table border="1"> <thead> <tr> <th colspan="2">TB21A</th> <th>Lunghezza   Length   Longitud</th> </tr> </thead> <tbody> <tr> <td>TB21A 10</td> <td></td> <td>3000 mm   118"7/64</td> </tr> <tr> <td>TB21A 12</td> <td></td> <td>6000 mm   236" 7/32</td> </tr> </tbody> </table>	TB21A		Lunghezza   Length   Longitud	TB21A 10		3000 mm   118"7/64	TB21A 12		6000 mm   236" 7/32
TB21A		Lunghezza   Length   Longitud									
TB21A 10		3000 mm   118"7/64									
TB21A 12		6000 mm   236" 7/32									

# Componenti

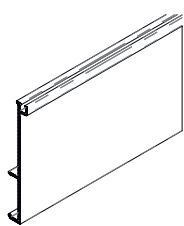
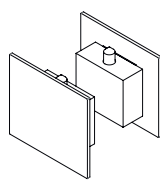
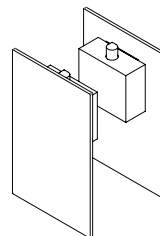
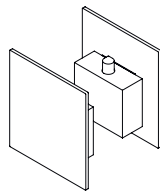
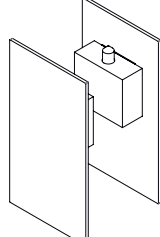
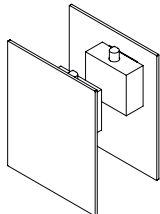
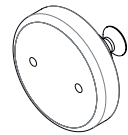
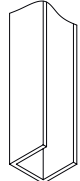
Components | Componentes

	<p><b>Copertina traversa</b> Frame cover Tapa Travesaños</p>	<p><b>TB22A</b> Lunghezza   Length   Longitud</p>												
		<table border="1"> <tr> <td>TB22A 10</td> <td>3000 mm   118"7/64</td> </tr> </table>	TB22A 10	3000 mm   118"7/64										
TB22A 10	3000 mm   118"7/64													
		<table border="1"> <tr> <td>TB22A 12</td> <td>6000 mm   236" 7/32</td> </tr> </table>	TB22A 12	6000 mm   236" 7/32										
TB22A 12	6000 mm   236" 7/32													
	<p><b>Kit 2 tappi app. a soffitto - su vetro fisso   Profilo porta 1</b> 2 End caps kit for ceiling and on sidelight installation   Door profile 1 Set de 2 tapitas lateral para guía para instalación de corredera a techo o su vidrio lateral   Perfil puerta 1</p>	<p><b>TB23A</b></p>												
	<p><b>Kit 2 tappi app. a soffitto - su vetro fisso   Profilo porta 2</b> 2 End caps kit for ceiling and on sidelight installation   Door profile 2 Set de 2 tapitas lateral para guía para instalación de corredera a techo o su vidrio lateral   Perfil puerta 2</p>	<p><b>TB24A</b></p>												
	<p><b>Kit 2 tappi app. a parete   Profilo porta 1</b> 2 End caps kit for wall installation   Door profile 1 Set de 2 tapitas lateral para guía para instalación de corredera a pared   Perfil puerta 1</p>	<p><b>TB25A</b></p>												
	<p><b>Kit 2 tappi app. a parete   Profilo porta 2</b> 2 End caps kit for wall installation   Door profile 2 Set de 2 tapitas lateral para guía para instalación de corredera a pared   Perfil puerta 2</p>	<p><b>TB26A</b></p>												
	<p><b>Kit 2 tappi app. a soffitto con vetro fisso   Profilo porta 2</b> 2 End caps kit for ceiling with sidelight installation   Door profile 1 Set de 2 tapitas lateral para guía para instalación de corredera a techo con vidrio fijo   Perfil puerta 1</p>	<p><b>TB27A</b></p>												
		<p><b>TB28A</b></p> <p><b>Kit Borchia per fissaggio vetro</b> Rosette kit for glass fixed panel Kit Tornillo para vidrio</p> 												
	<p><b>Canalina laterale vetro fisso</b> Side U-shaped profil Perfil en forma de U lateral</p> <table border="1"> <thead> <tr> <th>TBB2A</th> <th>Lunghezza   Length   Longitud</th> </tr> </thead> <tbody> <tr> <td>TBB2A 10</td> <td>3000 mm   118"7/64</td> </tr> <tr> <td>TBB2A 20</td> <td>6000 mm   236" 7/32</td> </tr> </tbody> </table>	TBB2A	Lunghezza   Length   Longitud	TBB2A 10	3000 mm   118"7/64	TBB2A 20	6000 mm   236" 7/32	 <p><b>Canalina a "U"</b> U-shaped profile Perfil en forma de U</p> <table border="1"> <thead> <tr> <th>TB33A</th> <th>Lunghezza   Length   Longitud</th> </tr> </thead> <tbody> <tr> <td>TB33A 10</td> <td>3000 mm   118"7/64</td> </tr> <tr> <td>TB33A 12</td> <td>6000 mm   236" 7/32</td> </tr> </tbody> </table>	TB33A	Lunghezza   Length   Longitud	TB33A 10	3000 mm   118"7/64	TB33A 12	6000 mm   236" 7/32
TBB2A	Lunghezza   Length   Longitud													
TBB2A 10	3000 mm   118"7/64													
TBB2A 20	6000 mm   236" 7/32													
TB33A	Lunghezza   Length   Longitud													
TB33A 10	3000 mm   118"7/64													
TB33A 12	6000 mm   236" 7/32													

# Condizioni generali di vendita

## General sales conditions

### 1 - ORDINI

La trasmissione di un ordine vale quale proposta di contratto. Speedycasma Srl provvederà a trasmettere conferma d'ordine in caso di accettazione con indicazione dei prezzi, dei termini di consegna e pagamento etc. La conferma d'ordine dovrà essere restituita controfirmata. L'evasione dell'ordine con invio della merce equivale ad accettazione e determina la conclusione del contratto anche in assenza di conferma d'ordine.

### 2 - PREZZI

Il prezzo applicato è quello risultante dal listino prezzi vigente alla data dell'ordine. I prezzi si intendono al netto dell'Iva, franco stabilimento. Speedycasma Srl può variare a propria discrezione il listino, senza alcun particolare obbligo di informazione. I prodotti in catalogo senza indicazione del prezzo sono da considerarsi prodotti speciali per i quali il prezzo deve essere di volta in volta concordato con la parte venditrice. Lo stesso vale per i prodotti fuori catalogo realizzati su precisa indicazione dell'acquirente per far fronte a sue specifiche esigenze.

### 3 - CONSEGNA

La consegna avviene franco fabbrica. L'accettazione del materiale senza riserve al momento della consegna non darà diritto ad alcuna sostituzione o risarcimento. In assenza di precise indicazioni dell'acquirente la merce verrà inviata al destinatario con un vettore scelto dalla venditrice. Le spese di trasporto, assicurazione ed ogni altro onere relativo all'inoltro della merce è a carico dell'acquirente. Il rischio relativo alla merce passa in capo al cliente nel momento della consegna della merce al vettore. I termini di consegna hanno valore indicativo, riflettendo condizioni normali di produzione suscettibili di variazione in fase di produzione della merce. I termini concordati in ogni caso decorrono dalla data della conferma d'ordine trasmessa da Speedycasma Srl. Nel caso in cui sia previsto il versamento di un acconto, i termini di consegna decorrono dal momento della ricezione di tale importo da parte del venditore. I ritardi nelle consegne, da qualsiasi causa dipendenti non danno diritto al risarcimento di danno alcuno. Ove il trasporto debba essere effettuato da vettore designato dal compratore, la merce dovrà essere ritirata presso i magazzini entro 15 gg, dalla data di comunicazione di merce pronta. In difetto, Speedycasma Srl potrà ritenere risolto il contratto non pregiudicando il diritto alla richiesta di risarcimento dei danni.

### 4 - MODALITA' DI PAGAMENTO

Il pagamento dovrà essere effettuato alle scadenze concordate ed indicate nella conferma d'ordine e nella successiva fattura. Speedycasma Srl ha facoltà di chiedere il versamento di un acconto all'ordine. Qualora l'ordine venga annullato o la merce non venga ritirata, o ritirata solo in parte, la somma versata quale acconto verrà trattenuta dalla Speedycasma Srl quale penale ex art.1382 c.c., fatto salvo il diritto alla richiesta di risarcimento di ulteriori danni.

Il ritardo nel pagamento rispetto alla scadenza pattuita determina automaticamente l'applicazione di un interesse di mora pari all'interesse legale maggiorato del 2%. In caso di ritardo nel pagamento Speedycasma Srl potrà sospendere tutti gli ordini da evadere sino al momento del pagamento. I termini per le consegne relative ad ordini sospesi decorrono dalla data del saldo del debito scaduto, con facoltà per Speedycasma Srl di rivedere i termini di pagamento concordati all'atto dell'accettazione della proposta.

### 5 - CONTESTAZIONI E GARANZIA

Speedycasma Srl garantisce (direttiva 1999/44/CE), che il prodotto è esente da difetti di fabbricazione, garantisce altresì il corretto funzionamento per la durata di due anni dalla data di acquisto. Al momento dell'arrivo della merce l'acquirente dovrà verificare la regolarità della stessa. Eventuali vizi palesi del prodotto devono essere denunciati per iscritto entro 8 gg dalla consegna a pena di decadenza. Lo stesso termine vale per i vizi occulti con decorrenza dal momento della scoperta. In ogni caso, eventuali contestazioni devono pervenire non oltre un anno dalla consegna. La venditrice, ove il vizio denunciato nei termini di cui sopra, sia effettivamente dovuto a vizio di produzione e non piuttosto al normale deterioramento per uso, negligenza, imperizia o abuso da parte dell'acquirente o dei suoi aventi causa, manomissioni o riparazioni effettuate da personale non autorizzato, caso fortuito o forza maggiore, provvederà gratuitamente a sostituire il prodotto difettoso accollandosi esclusivamente i costi del trasporto dello stesso fino alla sede dell'acquirente-rivenditore. Eventuali costi o danni ulteriori non potranno essere addebitati a Speedycasma Srl. Speedycasma Srl garantisce solo ed esclusivamente il prodotto fornito nei suoi componenti e non risponde d'uso improprio, in caso d'installazione e/o montaggio non conformi alle istruzioni date o non eseguite a regola d'arte. L'installatore professionista dovrà quindi tenere conto ed osservare scrupolosamente quanto specificato nelle schede tecniche e nelle istruzioni di montaggio, avendo cura di rispettare gli spessori vetro specificati e di effettuare una corretta esecuzione delle tacche e dei fori nel vetro, secondo le norme vigenti. Dovrà essere a cura dell'acquirente/installatore la verifica dell'integrità del prodotto e della sua conformità. In caso di difetti constatati dovranno essere comunicati per iscritto al rivenditore.

### 6 - FORO COMPETENTE

Per le controversie relative a validità, interpretazione, esecuzione e risoluzione del presente accordo competente esclusivamente il Foro di Milano.

### 7 - MINIMO FATTURABILE

I nostri prezzi sono in Euro. Ordini inferiori a €200,00 verranno fatturati a €200,00.

### 8 - IMBALLI

Fino ad un valore d'ordine netto di €2500,00 il costo dell'imballo verrà calcolato al costo in questi termini:

Costi degli imballi standard:

Scatole di cartone F4 EUR 3,00

Scatole di cartone F7 EUR 4,00

Scatole di cartone F20 EUR 20,00

Scatole di cartone F25 EUR 22,00

Scatole di cartone F30 EUR 25,00

Tubi di cartone diametro esterno 10cm EUR 17,00

Tubi di cartone diametro esterno 30cm EUR 20,00

Casse di legno fino ad una lunghezza di 1,50 m EUR 60,00

Casse di legno fino ad una lunghezza 3,00 m EUR 85,00

Casse di legno fino ad una lunghezza 4,50 m EUR 95,00

Casse di legno fino ad una lunghezza 6,50 m EUR 125,00

### 1 - ORDERS

The transmission of an order amounts to a contract proposal Speedycasma Srl will transmit its confirmation of order in case of acceptance, indicating the terms of delivery, prices, payment terms, etc. The order confirmation must be signed by the client and returned. Supply of the ordered goods amount to acceptance and stipulation of the contract even in the absence of the order confirmation.

### 2 - PRICES

The price applied is the price resulting from the price list in force as of the date of the order. Prices are net of VAT, delivered ex-works from the plant. Speedycasma Srl may modify its price list at its complete discretion, without any obligation to communicate and advertise the changes. The products in the catalogue without any price indication are to be considered special products. Their prices will be calculated case by case. This also applies to products that do not appear in the catalogue, produced onto purchaser requirements base.

### 3 - DELIVERY

Deliveries are made ex-works. Speedycasma will not be liable for any claim for replacement if the goods are received from the carrier without any reserve in writings. In the absence of any specific instructions from the purchaser, the goods will be shipped to their destination

by a carrier selected by the seller. Freight, insurance, and any other expenses relative to shipment of the goods will added to the invoice. The risks relative to the goods are transferred to the client at the time of delivery of the goods to the carrier. Delivery dates are indicative, reflecting normal production conditions susceptible to variation during production of the goods. The terms agreed in any case start from the date of the confirmation of order transmitted by Speedycasma Srl If any amount has to be paid as a deposit, the terms of delivery start from the time of receipt by the seller of the downpayment. Delays in delivery, whatever the cause, do not give any right to reimbursement of damages of any kind. If shipment is to be made by a carrier indicated by the buyer, the goods

must be collected from within 15 days from the date of notice that the goods are ready. Failing this, Speedycasma Srl may consider the contract cancelled, without any rights to reimbursement of the damages.

### 4 - PAYMENT TERMS

Payment must be made at the time agreed and indicated in the order confirmation. Speedycasma Srl has the right to request payment of a deposit. If the order is cancelled or the goods are not collected or are collected only in part, the deposit will be withheld by Speedycasma as a penalty as per art.1382 c.c. while the company retains the right to request reimbursement of additional damages. Delay in payment with respect to the agreed terms will automatically result in the application of interest charges at the legal rate plus 2%. In case of delayed payment Speedycasma Srl may also suspend all orders to be fulfilled until all due payments will be settled. The terms of deliveries relative to suspended orders shall start from the date of settlement of the payments. Speedycasma Srl in case of delayed payments has the right to revise the payment terms agreed upon at the time of acceptance of the order proposal.

### 5 - COMPLAINTS AND WARRANTY

Speedycasma Srl guarantees (Directive 1999/44 /CE) that the product is free of manufacturing defects, it also guarantees the correct functionality for a period of two years from the purchase date. Upon arrival of the goods the buyer has to check their conformity. Any apparent faults in the product shall be reported in writings within 8 days from delivery otherwise, the goods will be considered as accepted in full. The same terms apply for invisible flaws, from the time of their discovery. In any case, no claims will be accepted after one year from delivery. If the flaw, duly reported in writings, is effectively due to a production defect and not to a normal deterioration due to use, negligence, carelessness or abuse by the buyer or authorized users, tampering, repairs made by unauthorized parties, accidents or acts of God, the seller will provide to replace the defective product free of charge, as well as accepting the charges for return of the goods to the buyer-retailer. Any other costs or damages shall not be charged to Speedycasma Srl. Speedycasma Srl guarantees only ed exclusively the product, supplied with its component, and is not liable in case of improper use, of installation and / or mounting not complying with the instruction given, or not performed properly. The professional installer must therefore take into consideration and scrupulously observe what is specified in the technical sheets and the installing instruction, taking care to respect the specified glass thicknesses and to perform correct glass holes and notches, according to the regulations in force. The purchaser is liable of verification of the integrity of the products and their conformity. Any defects found must be communicated in writings to the dealer.

### 6 - LEGAL JURISDICTION

For any controversies relative to the validity, interpretation, performance or termination of this agreement the Court of Milan has exclusive legal jurisdiction.

### 7 - MINIMUM ORDER PER INVOICE

Our prices are declared in EURO. Order less than €200,00 will be invoiced at €200,00.

### 8 - PACKING

Up to a net order value of €2500,00 we calculate the packing at the cost price, but at least:

Standard Packing costs:

Carton Boxes F4 EUR 3,00

Carton Boxes F7 EUR 4,00

Carton boxes F20 EUR 20,00

Carton boxes F25 EUR 22,00

Carton Boxes F30 EUR 25,00

Carton Tubes OD 10cm EUR 17,00

Carton Tubes OD 30cm EUR 20,00

Wooden boxes with a length of up to 1,50 m EUR 60,00

Wooden boxes with a length of up to 3,00 m EUR 85,00

Wooden boxes with a length of up to 4,50 m EUR 95,00

Wooden boxes with a length of up to 6,50 m EUR 125,00





**Melbourne**  
170 Derrimut Drive  
Derrimut, VIC 3026  
03 9314 6105  
[sales@eliteglassolutions.com.au](mailto:sales@eliteglassolutions.com.au)

**Adelaide**  
7 Manfull Street  
Melrose Park, SA 5039  
08 8253 8700  
[sa@eliteglassolutions.com.au](mailto:sa@eliteglassolutions.com.au)